



**GRAESSNER**

MS-Graessner GmbH & Co. KG

THE GEAR COMPANY

# **DYNA** ***GEAR***



**DYNA** ***GEAR***  
*Dynamic and Precision*

**DYNA** ***GEAR*** *Economy*  
*The cost effective  
right angle servo gearbox*

[www.graessner.de](http://www.graessner.de)

A close-up, high-angle photograph of a bevel gear assembly. The image shows the intricate teeth of the gears and the shafts they are mounted on. The lighting is dramatic, highlighting the metallic surfaces and the precision of the manufacturing. A semi-transparent white rectangular box is overlaid on the upper portion of the image, containing text.

## **Precision combines with performance.**

Bevel gear technology is at the heart of an assembly consisting of gear housing, shafts, flanges and bearings resulting in a high performance gearbox. With over 50 years of experience, MS-GRAESSNER have the competence to offer innovative solutions in bevel gear technology and gearbox assembly suiting a wide range of industrial gearing applications. MS-GRAESSNER are the ideal partner for you.

# **Content**

	<i>Page</i>
<i>Highlights DynaGear</i>	<b>4–5</b>
<i>Performance tables DynaGear</i>	<b>6–7</b>
<i>Dimensions and versions DynaGear</i>	<b>8–9</b>
<i>Options DynaGear</i>	<b>10</b>
<i>DynaGear Economy</i>	<b>11</b>
<i>Highlights DynaGear Economy</i>	<b>12</b>
<i>Performance tables DynaGear Economy</i>	<b>13</b>
<i>Dimensions and versions DynaGear Economy</i>	<b>14–15</b>
<i>Selection</i>	<b>16</b>
<i>Inspection and maintenance</i>	<b>17</b>
<i>Ordering codes</i>	<b>18</b>

## Internal highlights

The design of the DynaGear range has been influenced by extremely varied applications within many industry sectors.

The DynaGear range has been developed with a highly dynamic servo drive solution in mind and therefore benefits from many advantages.

- Right angle gearbox, single-stage, ratios from 3:1 to 15:1; two-stage up to 150:1
- The compact and rigid design ensures highest performance whilst being space and weight efficient.
- Lubricated for life, the gearboxes are virtually maintenance-free (when used under normal conditions). A case of fit and forget.
- The high efficiency rating of 96% saves energy costs (92 % at DG-HR).



Weight efficient one-piece Aluminium housing ensures highest stability



High-quality taper roller bearings absorb axial and radial loads guaranteeing a long service life

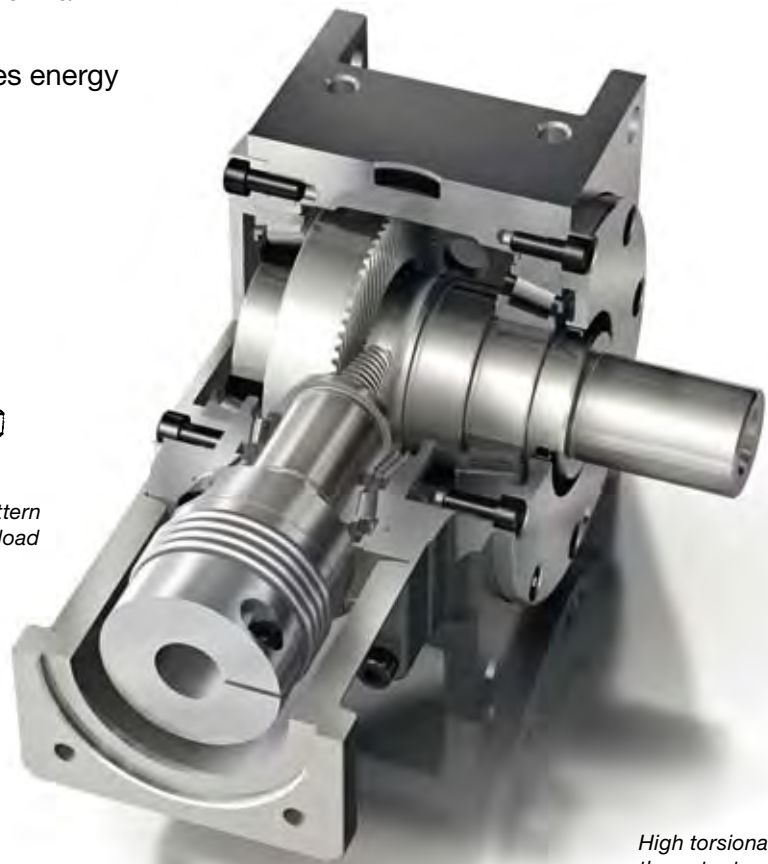

High torsional stiffness at the output

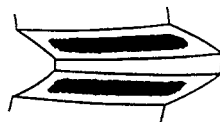

Optimized contact pattern assembly for uniform load distribution

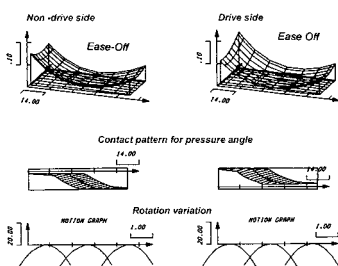

Optimized Gleason hypoid-gearing for high torque ratings and low backlash

Small moments of inertia at the input

Fretting- and backlash-free torque transfer using a friction-locked fit between shaft and hub

System optimization via variable torsional coupling stiffness

# External highlights

# DYNA GEAR

The DynaGear realises the theme “Motor – Coupling – Gearbox – Mounting” in a unique way.

- The DynaGear fits all current servo motors by way of flanges and couplings to suit.
- Torsional vibration can be adjusted via the coupling stiffness.
- The gearbox dimensions are identical for all ratios.

*Compact and weight efficient aluminium housing*

*Easy mounting without additional parts*

**Hollow shaft version without input flange**



*Largest possible integrated hollow shaft*

*Optimal centering at the mounting sides*

*Adaptor flanges and couplings to suit all motors*

*Subsequent motor type changes are possible ensuring highest flexibility*

**Solid shaft version without input flange**



**DynaGear HighRatio (HR) with planetary pre-stage; solid shaft version with input flange**



**Solid shaft with input flange, coupling and through shaft**



# Performance table/Technical data

# DYNA GEAR

DynaGear

Size		D55	D75	D90	D115	D130	D140	D160	D190
Ratio	i	3/4/5/6/8/10							
<b>Output torque</b>									
Nominal torque	$T_{2N}$ [Nm]	35	70	140	260	430	720	1100	1440
Maximum acceleration ④	$T_{2B}$ [Nm]	53	105	210	390	645	1080	1650	2160
Emergency stop torque ③	$T_{2Not}$ [Nm]	70	140	280	520	860	1440	2200	2880
Maximum input speed	$n_{1max}$ [min <sup>-1</sup> ]	8000	8000	7000	6000	5000	5000	4500	4500
Nominal input speed i = 3/4/5	$n_{1N}$ [min <sup>-1</sup> ]	2100	1800	1500	1150	1000	700	600	550
Nominal input speed i = 6/8/10	$n_{1N}$ [min <sup>-1</sup> ]	3200	2700	2200	1800	1500	1200	1100	1000
Standard backlash ①	$j_t$ [arcmin]	< 5	< 5	< 4	< 4	< 4	< 4	< 4	< 4
Reduced backlash ①	$j_t$ [arcmin]	< 3	< 3	< 2	< 2	< 2	< 2	< 2	< 2
Backlash stiffness at the output ⑤	$C_{t21}$ [Nm/arcmin]	2.1	4.2	10.5	23.4	39.6	61.8	90.0	126.0
Radial force ②	$F_{2Rmax}$ [N]	3300	4900	7200	10000	12600	15000	18000	22500
Axial force ②	$F_{2Amax}$ [N]	1650	2450	3600	5000	6300	7500	9000	11250
Efficiency rating at full load	$\eta$ [%]	> 96	> 96	> 96	> 96	> 96	> 96	> 96	> 96
Noise level ( $n_1=3000$ min <sup>-1</sup> )	$L_{pA}$ [dB(A)]	< 66	< 66	< 68	< 68	< 70	< 70	< 72	< 72
Weight approx.	m [kg]	3.5	5.5	9.5	15.5	23.5	32.5	46.5	60

Size		D55	D75	D90	D115	D130	D140	D160	D190
Ratio	i	12/15							
<b>Output torque</b>									
Nominal torque	$T_{2N}$ [Nm]	25	50	95	180	300	510	815	1020
Maximum acceleration ④	$T_{2B}$ [Nm]	38	75	143	270	450	765	1223	1530
Emergency stop torque ③	$T_{2Not}$ [Nm]	50	100	190	360	600	1020	1630	2040
Maximum input speed	$n_{1max}$ [min <sup>-1</sup> ]	8000	8000	7000	6000	5000	5000	4500	4500
Nominal input speed	$n_{1N}$ [min <sup>-1</sup> ]	3900	3300	2800	2300	2000	1600	1350	1300
Standard backlash ①	$j_t$ [arcmin]	< 5	< 5	< 4	< 4	< 4	< 4	< 4	< 4
Reduced backlash ①	$j_t$ [arcmin]	< 3	< 3	< 2	< 2	< 2	< 2	< 2	< 2
Backlash stiffness at the output	$C_{t21}$ [Nm/arcmin]	2.1	4.2	10.5	23.4	39.6	61.8	90.0	126.0
Radial force ②	$F_{2Rmax}$ [N]	3300	4900	7200	10000	12600	15000	18000	22500
Axial force ②	$F_{2Amax}$ [N]	1650	2450	3600	5000	6300	7500	9000	11250
Efficiency rating at full load	$\eta$ [%]	> 93	> 93	> 93	> 93	> 93	> 93	> 93	> 93
Noise level ( $n_1=3000$ min <sup>-1</sup> )	$L_{pA}$ [dB(A)]	≥ 66	≥ 66	≥ 68	≥ 68	≥ 70	≥ 70	≥ 72	≥ 72
Weight approx	m [kg]	3.5	5.5	9.5	15.5	23.5	32.5	46.5	60

Size		D55HR	D75HR	D90HR	D115HR	D130HR	D140HR	D160HR	D190HR
Ratio	i ⑥	18/24/30/40/50/60/80/100							
<b>Output torque</b>									
Nominal torque	$T_{2N}$ [Nm]	35	70	140	260	430	720	1100	1440
Maximum acceleration ④	$T_{2B}$ [Nm]	53	105	210	390	645	1080	1650	2160
Emergency stop torque ③	$T_{2Not}$ [Nm]	70	140	280	520	860	1440	2200	2880
Maximum input speed	$n_{1max}$ [min <sup>-1</sup> ]	6000	6000	6000	6000	5000	5000	4500	4500
Nominal input speed	$n_{1N}$ [min <sup>-1</sup> ]	3500	3000	3000	2500	2500	2500	2500	2500
Standard backlash ①	$j_t$ [arcmin]	< 7	< 7	< 6	< 6	< 6	< 6	< 6	< 6
Reduced backlash ①	$j_t$ [arcmin]	< 5	< 5	< 3	< 3	< 3	< 3	< 3	< 3
Backlash stiffness at the output	$C_{t21}$ [Nm/arcmin]	2.1	4.1	10.2	22.8	37.8	60.1	86.5	119.2
Radial force ②	$F_{2Rmax}$ [N]	3300	4900	7200	10000	12600	15000	18000	22500
Axial force ②	$F_{2Amax}$ [N]	1650	2450	3600	5000	6300	7500	9000	11250
Efficiency rating at full load	$\eta$ [%]	> 92	> 92	> 92	> 92	> 92	> 92	> 92	> 92
Noise level ( $n_1=3000$ min <sup>-1</sup> )	$L_{pA}$ [dB(A)]	< 66	< 66	< 68	< 68	< 70	< 70	< 72	< 72
Weight approx	m [kg]	4.0	6.5	12.5	19.5	27	36	49	61.5

Service life (SL) [h]: > 30.000 based operation mode S5  
 Lubrication: Lubricated for life, closed system  
 Mounting positions: Any  
 Operation temperature: -10 °C to 100 °C  
 Paint: Primary coated RAL 9005 – black  
 Ex-protection / type of protection: Ex II 2 D / G T4 / IP 64

① At the output, at 2 % load  
 ② Resulting force centre of output shaft at output speed 400 min<sup>-1</sup>  
 ③ Max 1000 times during the service life of the gearbox

④ At max 1000 cycles per hour, please consider reducing factor in other cases  
 ⑤ At nominal torque (DynaGearHR with coupling)  
 ⑥ Ratios 120:1 and 150:1 on request

# Performance table/Technical data

# DYNA GEAR

Mass moment of inertia  $I_1$   
related to input [kgcm<sup>2</sup>]

## DynaGear<sup>®</sup>

Ratio i	Size							
	D55	D75	D90	D115	D130	D140	D160	D190
3:1	0.39	0.98	2.42	7.12	14.03	26.96	52.32	91.47
4:1	0.30	0.73	1.77	5.09	9.17	17.44	32.78	62.43
5:1	0.23	0.58	1.41	4.00	7.12	13.53	24.76	44.29
6:1	0.22	0.52	1.41	3.65	6.76	12.25	22.49	39.55
8:1	0.17	0.43	1.12	2.85	5.09	8.95	15.67	27.07
10:1	0.15	0.38	1.00	2.46	4.27	7.38	12.47	21.43
12:1	0.14	0.36	0.88	2.25	3.81	6.47	10.67	18.14
15:1	0.13	0.34	0.81	2.07	3.45	5.76	9.23	15.53

<sup>®</sup> Values without coupling

## DynaGear HR

Ratio i	Size							
	D55HR	D75HR	D90HR	D115HR	D130HR	D140HR	D160HR	D190HR
16:1	0.40	1.19	1.25	5.12	5.37	8.74	9.70	11.55
18:1	0.46	1.38	1.41	6.64	6.73	12.57	12.85	13.33
24:1	0.39	1.15	1.18	4.90	4.99	7.99	8.27	8.75
30:1	0.37	1.06	1.09	4.15	4.24	6.58	6.86	7.34
32:1	0.38	1.15	1.16	4.84	4.88	7.79	7.89	8.07
40:1	0.36	1.06	1.07	4.09	4.13	6.38	6.48	6.66
50:1	0.36	1.05	1.06	4.07	4.09	6.31	6.36	6.45
60:1	0.35	0.94	0.97	3.20	3.29	4.14	4.42	4.90
80:1	0.34	0.94	0.95	3.14	3.18	3.94	4.04	4.22
100:1	0.34	0.93	0.94	3.12	3.14	3.87	3.92	4.01

## Input without flange, without coupling

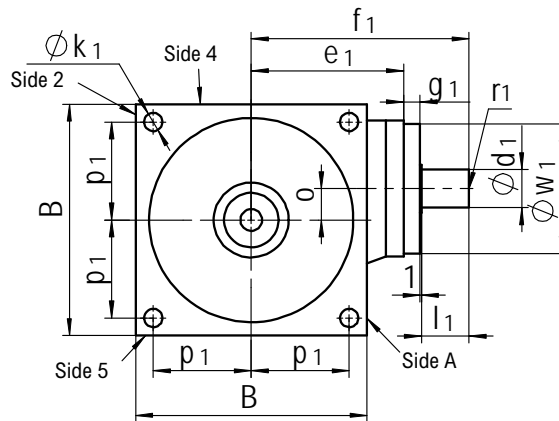
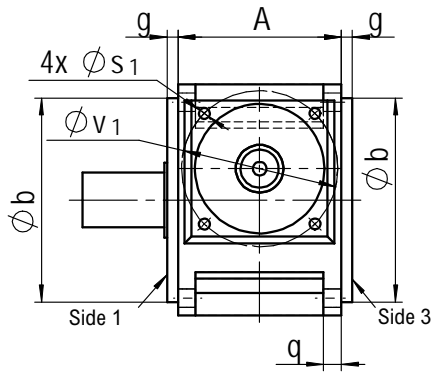

## Input with flange and coupling i = 3-15

## Input with planetary pre-stage i = 16-100

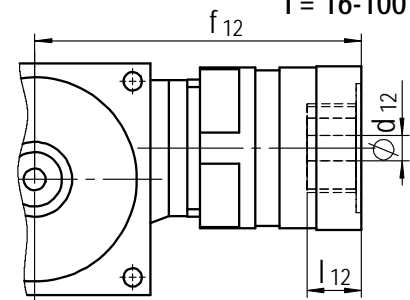
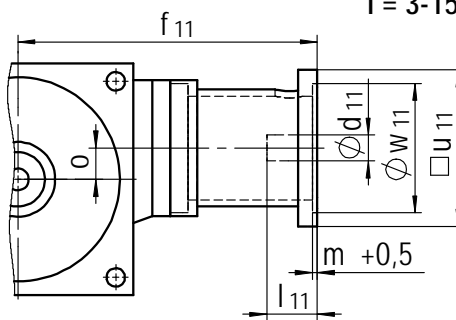
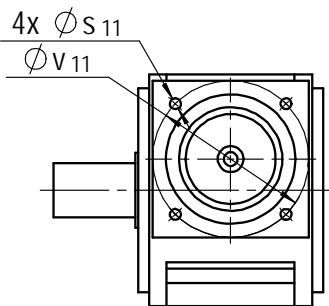

## Output with solid shaft

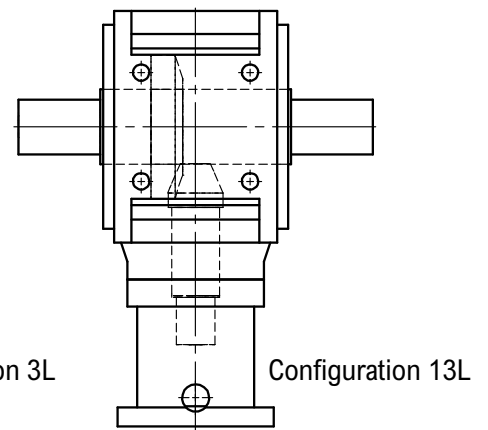
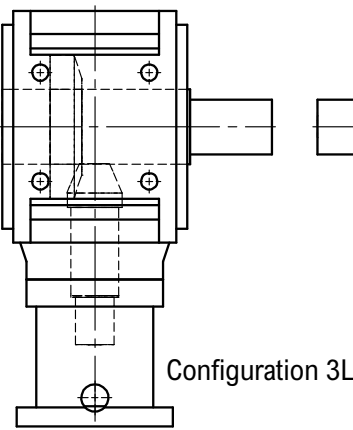
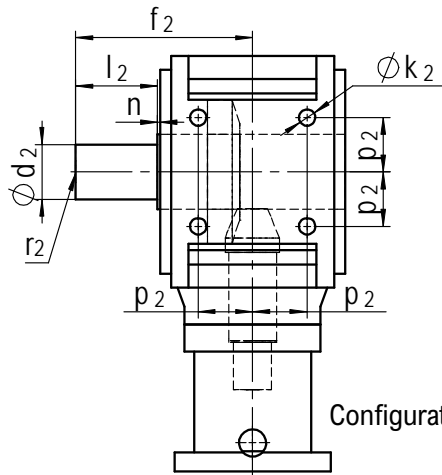

## Output with hollow shaft

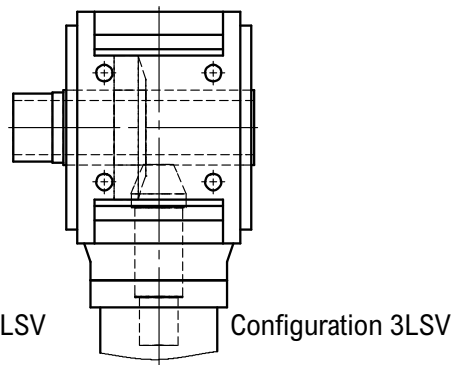
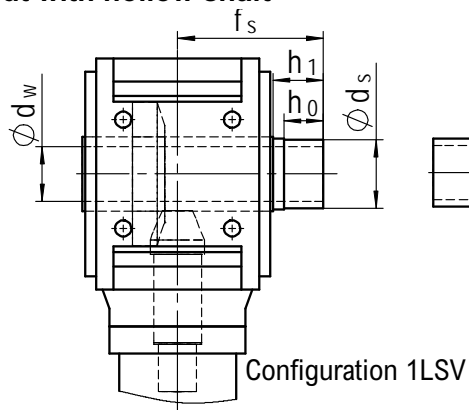

Size	A	B	Ø b <sub>g6</sub>	g	o	p <sub>1</sub>	p <sub>2</sub>	Ø k <sub>1</sub>	k <sub>2</sub>	q
D55	60	90	89	13.5	9	39	22	6.6	M6	8
D75	80	115	105	8.5	14	49	27	9	M8	10
D90	100	140	125	8	18	59	33	11	M10	11
D115	120	170	150	8	23	72	40	13.5	M12	13
D130	138	192	173	10	27	82	47.5	13.5	M12	14
D140	146	215	195	10	32	91	52	17.5	M16	15
D160	166	240	225	10	38	103	60	17.5	M16	16
D190	196	260	245	10	42	112	70	17.5	M16	17

## Input without input flange and without coupling

Size	Ø d <sub>1 k6</sub>	l <sub>1</sub>	r <sub>1</sub> ⊙	Ø w <sub>1 g6</sub>	g <sub>1</sub>	Ø v <sub>1</sub>	s <sub>1</sub>	f <sub>1</sub>	e <sub>1</sub>
D55	14	15	M5	46	4	67	M6	101	81
D75	18	25	M6	73	11	90	M6	123	86
D90	22	30	M8	85	12	103	M8	139	96
D115	28	35	M10	95	12	115	M8	160	112
D130	32	36	M12	109	14	130	M10	177	126
D140	32	38	M12	119	16	145	M10	197	142
D160	36	42	M12	126	16	153	M10	217	158
D190	40	45	M16	137	16	165	M12	236	174

## Input with flange and coupling

Size	Ø d <sub>1</sub> x l <sub>1</sub>			□ u x f <sub>1</sub> ⊕		
D55	9x23	11x26	14x30	55x130	75x140	90x180
D75	11x26	14x30	19x40	75x168	90x168	90x180
D90	14x30	19x40	24x50	90x191	115x191	115x201
D115	19x40	24x50	32x60	115x220	140x220	140x235
D130	24x50	32x60	38x80	140x245	190x245	190x260
D140	24x50	32x60	38x80	140x260	190x260	190x280
D160	32x60	38x80	48x80	140x298	190x308	260x308
D190	32x60	38x80	48x80	190x335	260x345	

} Pitch circle diameter, centering diameter, thread and centering depth according to the relevant motor data sheet

## Input with planetary pre-stage for motor shaft and input flange

Size	Ø d <sub>12</sub> x l <sub>12</sub> x f <sub>12</sub>
D55HR	9x25x153.3 / 11x25x153.3 / 14x30x158.3
D75HR	14x30x186.6 / 19x40x196.6 / 24x50x206.6
D90HR	14x30x202.6 / 19x40x212.6 / 24x50x222.6
D115HR	19x40x241 / 24x50x251 / 32x60x261 / 35x80x281
D130HR	19x40x257 / 24x50x267 / 32x60x277
D140HR	24x50x300 / 32x60x310 / 38x80x330
D160HR	24x50x320 / 32x60x330 / 38x80x350
D190HR	24x50x339 / 32x60x349 / 38x80x369

} Square □ u, the pitch circle diameter Ø v with threads s and the centering diameter Ø w with length m are motor dependent.  
Please contact us!

## Output with solid shaft

Size	Ø d <sub>2 k6</sub>	l <sub>2</sub>	f <sub>2</sub>	n	r <sub>2</sub> ⊙
D55	20	35	80	1,5	M6
D75	24	40	90	1,5	M8
D90	32	50	110	2	M12
D115	40	60	130	2	M16
D130	48	75	156	2	M16
D140	55	90	175	2	M20
D160	60	100	195	2	M20
D190	70	110	220	2	M20

## Output with hollow shaft<sup>Ⓢ</sup>

Size	Ø d <sub>w H7</sub>	Ø d <sub>s f7</sub>	h <sub>0</sub>	h <sub>1</sub>	f <sub>s</sub>
D55	20	24	20	23	71,5
D75	25	30	22	25	79,5
D90	30	36	26	29	93
D115	40	50	29	33	107
D130	48	55	32	37	121
D140	55	68	32	37	127
D160	60	75	34	40	139
D190	70	80	34	40	159

Ⓢ Standard square for relevant motor type

⊙ According to D DIN 332

Ⓢ Extended shaft for the shrink disk (e.g. Stüwe – Type HSD 22)  
Delivery with shrink disk on request

We reserve the right to undertake technical changes

# Options

## Block flange to EN ISO 9409-1

# DYNA GEAR

Size	Position	Pitch circle $\phi$ d1		$\phi$ d <sub>2</sub> h8	$\phi$ d <sub>3</sub> H7	$\phi$ d <sub>4</sub>	$\phi$ d <sub>5</sub> H7	$\phi$ d <sub>7</sub>	f <sub>2</sub>	t <sub>1</sub>
		Series 1	Series 2							
D55	3	40	–	50	25	M6	6	89	57	7
D75	4	–	50	63	31.5	M6	6	105	62.5	7
D90	5	63	–	80	40	M6	6	125	73	7
D115	6	–	80	100	50	M8	8	150	87	10
D130	6	–	80	100	50	M8	8	173	96.5	10
D140	7	100	–	125	63	M8	8	195	100.5	10
D160	7	100	–	125	63	M8	8	225	115	12
D190	8	–	125	160	80	M10	10	245	132.5	12

	t <sub>2</sub>	t <sub>3</sub>	t <sub>4</sub>	t <sub>6</sub>	t <sub>7</sub>	t <sub>8</sub>	t <sub>9</sub>	N
D55	6.5	6.5	Thread depth > 1.5 $\phi$ d <sub>4</sub>	1	45	45	20	7
D75	6.5	6.5		1	45	45	15.5	7
D90	6.5	6.5		1	45	45	16	7
D115	8.5	8.5		1	30	30	17	11
D130	8.5	8.5		1	30	30	17.5	11
D140	8.5	8.5		1	30	30	17.5	11
D160	8.5	8.5		1	30	30	20	11
D190	10.5	8.5		1	30	30	22.5	11

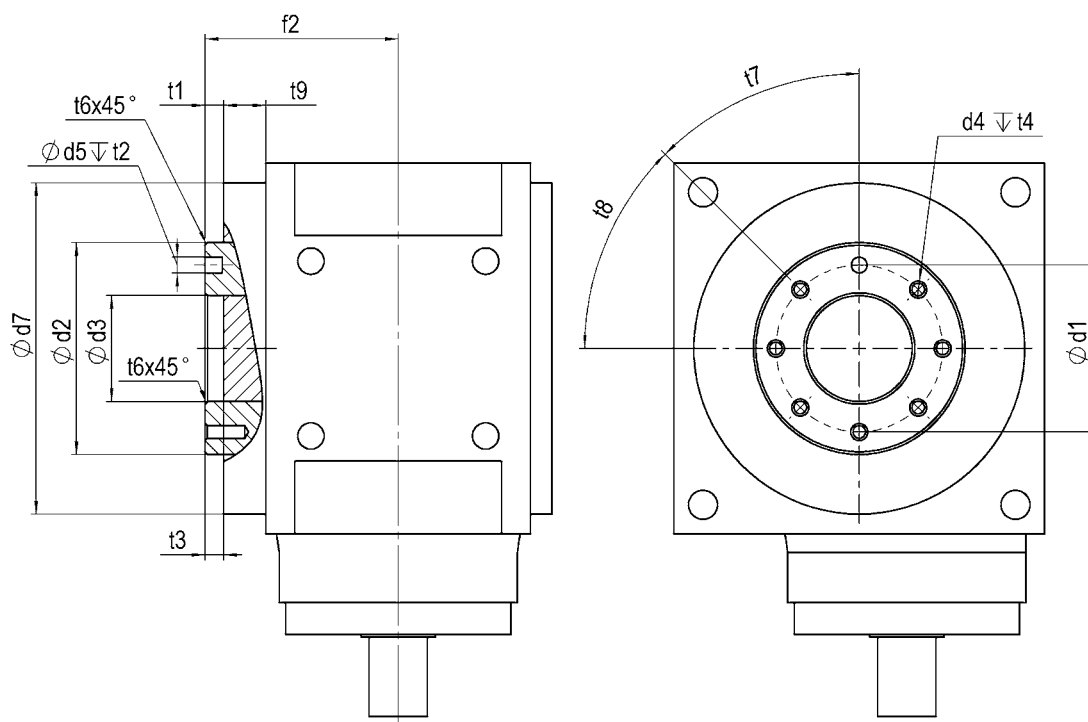

### Low noise gearbox version

Size	D55	D75	D90	D115	D130	D140	D160	D190
Noise level [dB(A)] (n <sub>1</sub> = 3000 min <sup>-1</sup> )	< 64	< 64	< 66	< 66	< 67	< 67	< 68	< 69

Gearbox with backlash < 1 arc min

available on request

# **DYNA GEAR** *Economy*

***The cost-effective right  
angle servo gearbox***



# Highlights

The design of the DynaGear Economy range has been influenced by extremely varied applications within many industry sectors.

The DynaGear Economy range has been developed with a dynamic servo drive solution in mind and therefore benefits from many advantages.

- Right angle gearbox, single-stage, ratios 5:1, 8:1, 10:1 and 15:1.
- The compact and rigid design ensures highest performance whilst being space and weight efficient.
- Lubricated for life, the gearboxes are virtually maintenance-free (when used under normal conditions).
- The high efficiency rating of up to 96% saves energy costs



*Weight efficient one-piece Aluminium housing ensures highest stability*

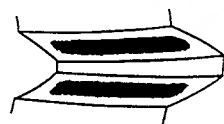
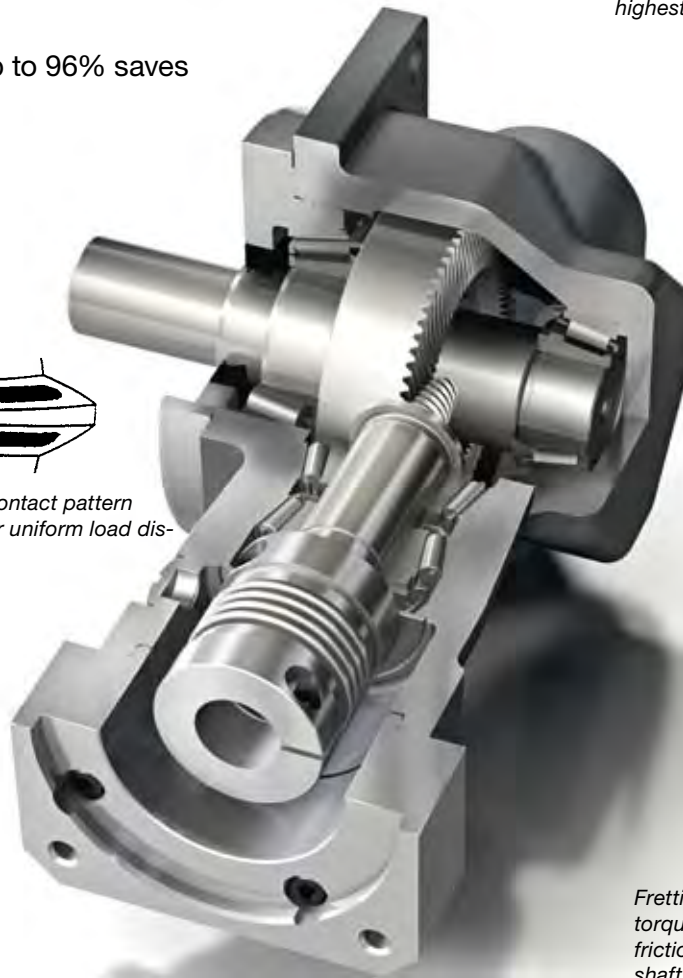

*Optimized contact pattern assembly for uniform load distribution*

*High torsional stiffness at the output*

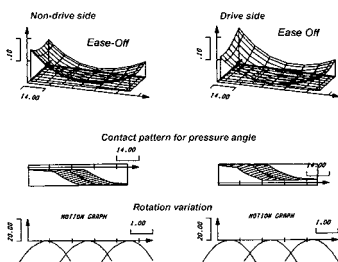

*Optimized Gleason hypoid-gearing for high torque ratings and low backlash*

*Fretting- and backlash-free torque transfer using a friction-locked fit between shaft and hub*

*Small moments of inertia at the input*

*System optimization via variable torsional coupling stiffness*

# Performance table/Technical data

**DYNA GEAR** *Economy*

## DynaEco DE-DG

Size		DE-DG55	DE-DG75	DE-DG90	DE-DG115	DE-DG55	DE-DG75	DE-DG90	DE-DG115
Ratio	i	5/8/10				15			
Output torque									
Nominal torque	$T_{2N}$ [Nm]	35	70	140	260	25	50	95	180
Maximum acceleration ④	$T_{2B}$ [Nm]	53	105	210	390	38	75	143	270
Emergency stop torque ③	$T_{2Not}$ [Nm]	70	140	280	520	50	100	190	360
Maximum input speed	$n_{1max}$ [min <sup>-1</sup> ]	6000	6000	5000	4000	6000	6000	5000	4000
Nominal input speed i = 5/8	$n_{1N}$ [min <sup>-1</sup> ]	3100	2400	2100	1820	–	–	–	–
Nominal input speed i = 10/15	$n_{1N}$ [min <sup>-1</sup> ]	3800	2900	2600	2250	3800	2900	2600	2250
Backlash ①	$j_t$ [arcmin]	< 7	< 7	< 6	< 6	< 7	< 7	< 6	< 6
Backlash stiffness at output ⑤	$C_{t21}$ [Nm/arcmin]	2.5	5.0	12.0	28.0	2.5	5.0	12.0	28.0
Radial force ②	$F_{2Rmax}$ [N]	3300	4900	7200	10000	3300	4900	7200	10000
Axial force ②	$F_{2Amax}$ [N]	1650	2450	3600	5000	1650	2450	3600	5000
Efficiency rating at full load	$\eta$ [%]	> 96	> 96	> 96	> 96	> 93	> 93	> 93	> 93
Noise level ( $n_1=3000$ min <sup>-1</sup> )	$L_{pA}$ [dB(A)]	< 66	< 66	< 68	< 68	< 66	< 66	< 68	< 68
Weight approx	m [kg]	2.5	4.2	8.2	13.5	2.5	4.2	8.2	13.5

## DynaEco DE-PL

Size		DG-PL55	DE-PL75	DE-PL90	DE-PL 115	DE-PL55	DE-PL75	DE-PL90	DE-PL115
Ratio	i	5/8/10				15			
Output torque									
Nominal torque	$T_{2N}$ [Nm]	35	70	140		25	50	95	
Maximum acceleration ④	$T_{2B}$ [Nm]	53	105	210		38	75	143	
Emergency stop torque ③	$T_{2Not}$ [Nm]	70	140	280		50	100	190	
Maximum input speed	$n_{1max}$ [min <sup>-1</sup> ]	6000	6000	5000		6000	6000	5000	
Nominal input speed i = 5/8	$n_{1N}$ [min <sup>-1</sup> ]	3100	2400	2100		–	–	–	
Nominal input speed i = 10/15	$n_{1N}$ [min <sup>-1</sup> ]	3800	2900	2600		3800	2900	2600	
Backlash ①	$j_t$ [arcmin]	< 7	< 7	< 6		< 7	< 7	< 6	
Backlash stiffness at output ⑤	$C_{t21}$ [Nm/arcmin]	2.5	5.0	12.0		2.5	5.0	12.0	
Radial force ②	$F_{2Rmax}$ [N]	2200	4050	6200		2200	4050	6200	
Axial force ②	$F_{2Amax}$ [N]	1100	2025	3100		1100	2025	3100	
Efficiency rating at full load	$\eta$ [%]	> 96	> 96	> 96		> 93	> 93	> 93	
Noise level ( $n_1=3000$ min <sup>-1</sup> )	$L_{pA}$ [dB(A)]	< 66	< 66	< 68		< 66	< 66	< 68	
Weight approx	m [kg]	2.6	4.5	9.0		2.6	4.5	9.0	

Service life (SL) [h]: > 15.000 based on operation mode S5  
 Lubrication: Lubricated for life, closed system  
 Mounting positions: Any  
 Operation temperature: -10 °C to 100 °C  
 Paint: Primary coated RAL 9005 – black  
 Ex-protection / type of protection: Ex II 2 D/G T4 / IP 64

① At the output, at 2 % load

② Resulting force centre of output shaft at output speed 400 min<sup>-1</sup>

③ Max 1000 times during the service life of the gearbox

④ At max 1000 cycles per hour, please consider reducing factor in other cases

## Mass moment of inertia $I_1$ related to input [kgcm<sup>2</sup>]

(coupling included)

Ratio i	Size						
	DE-DG55	DE-DG75	DE-DG90	DE-DG115	DG-PL55	DE-PL75	DE-PL90
5:1	0.44	1.06	3.6	7.2	0.44	1.07	3.7
8:1	0.37	0.88	3.0	5.7	0.37	0.89	3.0
10:1	0.35	0.84	2.9	5.3	0.35	0.84	2.9
15:1	0.33	0.79	2.7	4.9	0.33	0.79	2.7

# Dimensions and Configurations DE-DG

**DYNA GEAR** *Economy*

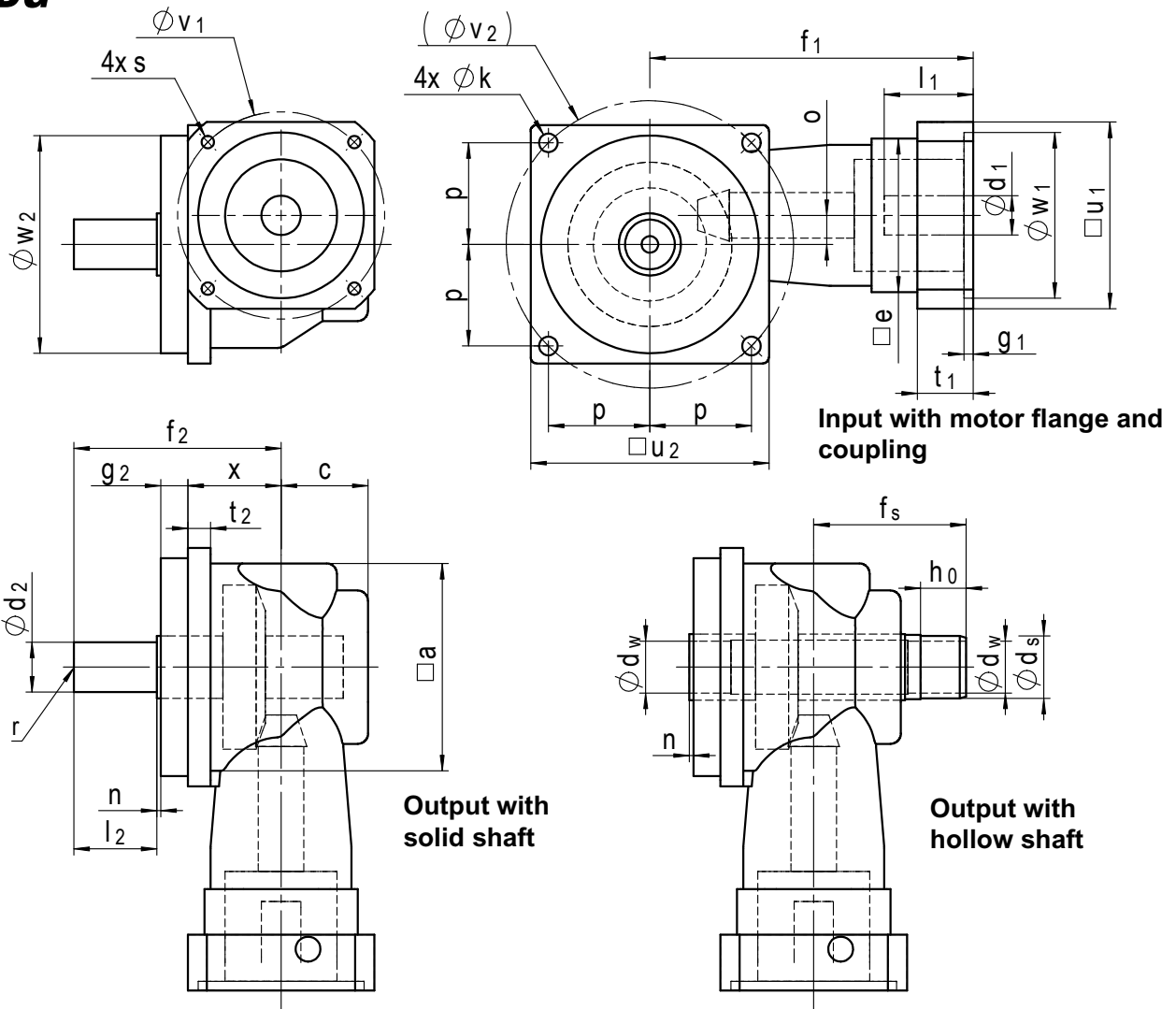

Size	$\square a$	$c$	$x$	$o$	$\square e$	$f_1$	$g_1$	$t_1$	$g_2$	$t_2$	$\phi k$	$p$	$\square u_2$	$\phi v_2$	$\phi w_2$ g6
DE-DG55	84	36	37	9	58	130	4.5	20	13	9	6.6	39	90	110.3	89
DE-DG75	100	42	45	14	74	156	4.5	27	13	11	9	49	115	138.6	105
DE-DG90	125	52	58	18	89	187	4.5	33	16	14	11	59	140	166.9	125
DE-DG115	150	63	71	23	107	225	6	40	16	17	13.5	72	170	203.6	150

## Input with motor flange and coupling

Size	Version	$\phi d_1$	$l_1$	$\square u_1$	$\phi v_1$	$\phi w_1$ F7	$s$
DE-DG55	V1	9	23	60	63	40	M4
	V2	11	26	75	75	60	M5
	V3	14	33	75	75	60	M5
DE-DG75	V1	11	26	75	75	60	M5
	V2	14	33	75	75	60	M5
	V3	19	43	90	100	80	M6
DE-DG90	V1	14	33	90	100	80	M6
	V2	19	43	90	100	80	M6
	V3	24	53	115	130	110	M8
DE-DG115	V1	19	43	115	130	110	M8
	V2	24	53	115	130	110	M8
	V3	32	63	140	165	130	M10

## Output with solid shaft

Size	$\phi d_2$ k6	$l_2$	$f_2$	$n$	$r^{\text{①}}$
DE-DG55	20	35	87	2	M6
DE-DG75	24	40	100	2	M8
DE-DG90	32	50	126	2	M12
DE-DG115	40	60	146	2	M16

## Output with hollow shaft<sup>②</sup>

Size	$\phi d_w$ H7	$\phi d_s$ f7	$h_0$	$f_s$	$n$
DE-DG55	20	24	20	64.5	2
DE-DG75	25	30	22	73.5	2
DE-DG90	30	36	26	87	2
DE-DG115	40	50	29	102	2

① To D DIN 332

② Extended shaft for a shrink disk (e.g. Stüwe – Type HSD 22)  
Delivery with shrink disk on request

We reserve the right to undertake technical changes

# Dimensions and Configurations DE-PL

**DYNA GEAR** *Economy*

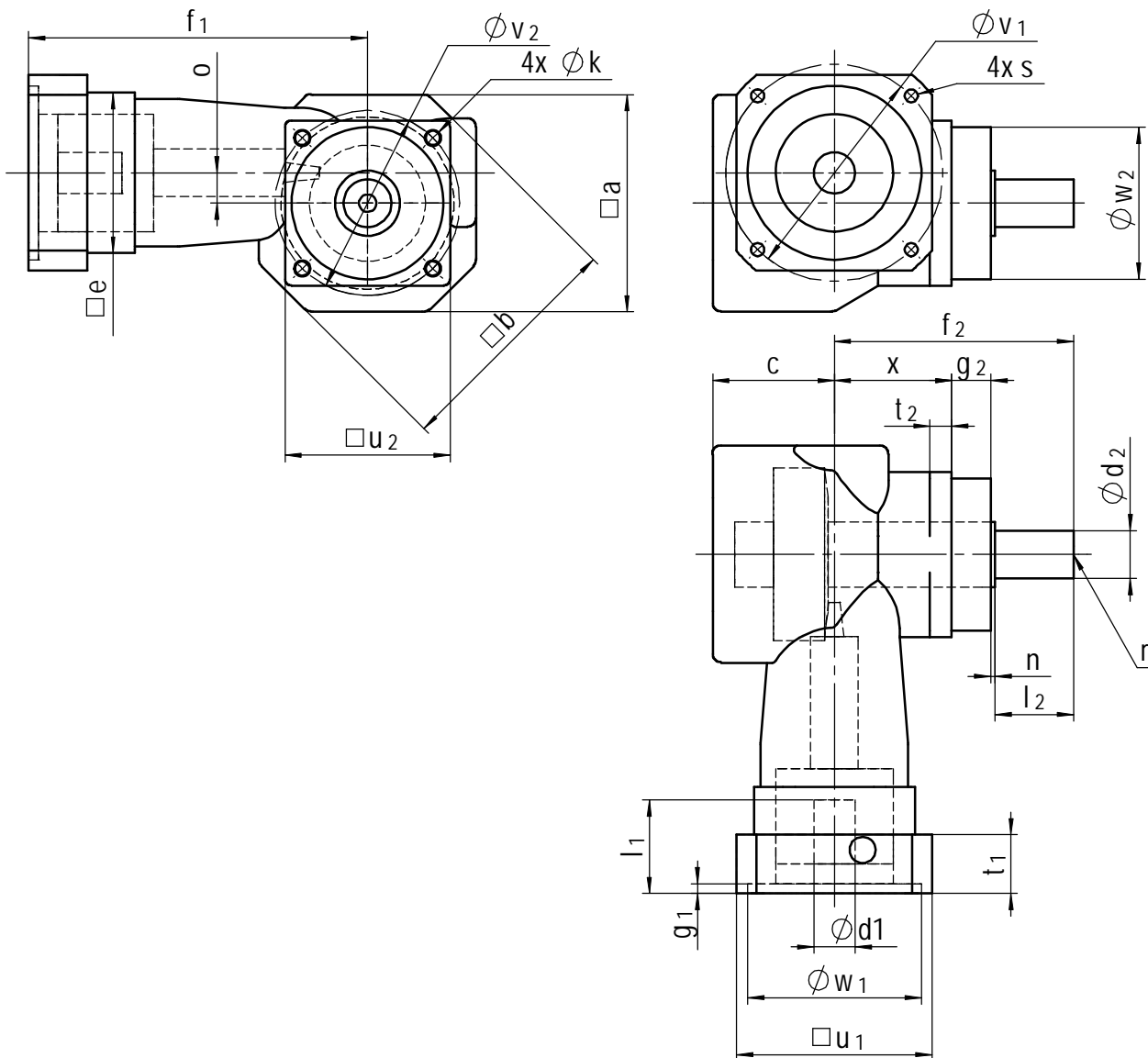

Size	$a$	$b$	$c$	$x$	$o$	$e$	$f_1$	$g_1$	$t_1$	$g_2$	$t_2$	$\phi k$	$u_2$	$\phi v_2$	$\phi w_2$ g6
DE-PL55	84	91.5	46.5	47	9	58	130	4.5	20	18	8.5	5.5	66	68	60
DE-PL75	100	110	56	54	14	74	156	4.5	27	18	10	6.5	76	85	70
DE-PL90	125	139	68	68	18	89	187	4.5	33	20	13	9	101	120	90

## Input with motor flange and coupling

Size	Version	$\phi d_1$	$l_1$	$u_1$	$\phi v_1$	$\phi w_1$ F7	$s$
DE-PL55	V1	9	23	60	63	40	M4
	V2	11	26	75	75	60	M5
	V3	14	33	75	75	60	M5
DE-PL75	V1	11	26	75	75	60	M5
	V2	14	33	75	75	60	M5
	V3	19	43	90	100	80	M6
DE-DG90	V1	14	33	90	100	80	M6
	V2	19	43	90	100	80	M6
	V3	24	53	115	130	110	M8

## Output with solid shaft

Size	$\phi d_2$ k6	$l_2$	$f_2$	$n$	$r^{\ominus}$
DE-DG55	16	28	95	2	M5
DE-DG75	22	36	110	2	M8
DE-DG90	32	58	148	2	M12

⊖ To D, DIN 332

We reserve the right to undertake technical changes

# Selection

For entire DynaGear range

# DYNA GEAR

Operation mode S5 duty cycle (dc) < 60 % or run time (RT) < 20 min

Maximum existing motor acceleration torque  $T_{1B\text{Mot}}$  [Nm]



Calculate the maximum existing acceleration torque at the gearbox output

$$T_{2B\text{max exist.}} = T_{1B\text{Mot}} \times i \text{ [Nm]}$$



Compare the maximum existing acceleration torque at the gearbox output with the permissible acceleration torque at the gearbox output

$$T_{2B\text{max exist.}} \leq T_{2B\text{perm.}} \times k$$



Existing average speed  $n_{1\text{exist.}} \leq$  nominal speed  $n_{1N}$

Valid for an average torque of 30 % of the permissible output torque  $T_{2N}$



Compare the motor dimensional details such as flange size, shaft diameter and shaft length with the gearbox dimensions  $\square u, d_1, l_1$  [mm]



Compare the radial and axial shaft load with the maximum permissible values

$$F_{R2\text{exist.}} \leq F_{R2\text{max}} \text{ [N]} \quad F_{A2\text{exist.}} \leq F_{A2\text{max}} \text{ [N]}$$

These are guide values, dependent on additional loads. Upon request we calculate these values individually.

For continuous operation S1, please contact us.

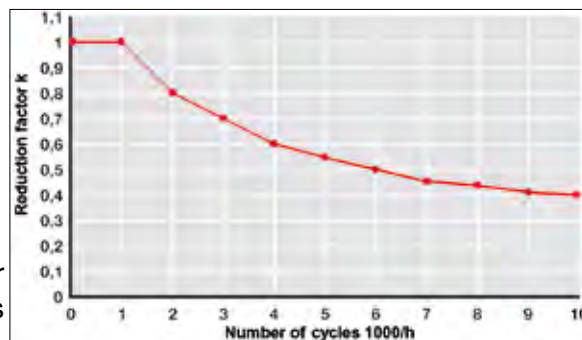

Reduction factor for high number of cycles

## Example: Positioning drive

Given: Servo motor  $T_{1B\text{max}} = 16 \text{ Nm}$   
Ratio  $i = 8:1$   
No of cycles 2000/h

Selection:  $T_{2B \text{ max. exist.}} = 16 \text{ Nm} \times 8 = 128 \text{ Nm}$   
Gearbox D90 8:1 1L  
 $T_{2B \text{ max exist.}} \leq T_{2B \text{ zul}} \times k$   
 $128 \text{ Nm} \leq 210 \text{ Nm} \times 0.8 = 168 \text{ Nm}$

Connection dimensions

Motor: Flange  $\square 105 \text{ mm}$ , shaft  $d_1 = \text{Ø } 19 \text{ mm}$ ,  $l_1 = 40 \text{ mm}$

Gearbox: Flange  $\square 115 \text{ mm}$ , shaft  $d_1 = \text{Ø } 19 \text{ mm}$ ,  $l_1 = 40 \text{ mm}$

**Selected: D90 8:1 1L**

## **DynaGear and DynaGear Economy Gearboxes**

DYNAGEAR gearboxes are supplied ready lubricated for life with a high-quality synthetic oil to CLP DIN 51 517, ISO VG-Class 150 (DIN 51 519). They are therefore maintenance free.

We recommend that for continuous operation close to the thermal performance limit, regular leak controls are undertaken on the shaft seals. After approx 15.000 operating hours, it is advisable to change the oil. Please request instructions which also include advice on lubricants and quantity. Service kits of wear and tear parts with full instructions are available from our service department.

## **DynaGear High Ratio Gearboxes**

DYNAGEAR High Ratio Gearboxes have two separate lubrication chambers.

The hypoid stage is lubricated with a high-quality synthetic oil (synthetic hydrocarbon plus additives) to CLP DIN 51517, ISO VG-Class 150 (DIN 51 519).

The planetary stage is filled with a special grease, consistency 00 to DIN 51818.

If used under normal conditions, the gearboxes are considered lubricated for life and are therefore maintenance-free.

We recommend that for continuous operation close to the thermal performance limit, regular leak controls are undertaken on the shaft seals. After approx 15,000 operating hours, it is advisable to change the both the oil and the grease. The gearboxes require disassembly in order to change the lubricants. We will be happy to carry out this work for you at our factory. Should you still wish the change the lubricants yourself, please request instructions which also include advice on lubricants and quantity. Service kits of wear and tear parts with full instructions are available from our service department.

# Ordering Example

**DYNA GEAR**

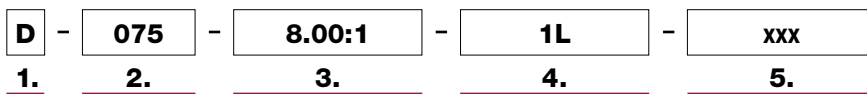

- 1. Gearbox range** D = DynaGear Page 6+7  
D..HR = DynaGear High Ratio Page 6+7  
DE-DG = DynaGear Economy DG Page 13  
DE-PL = DynaGear Economy PL Page 13

**2. Size**

**3. Ratio**

- 4. Configuration** See pages 8, 14, 15

- 5. Additional data**
- Input speeds  
Maximum application speed
  - Options – if required
  - Customised design – if required

**Please include the relevant motor data sheet.**



**Germany**

**MS-GRAESSNER GmbH & Co. KG**  
**THE GEAR COMPANY**  
Kuchenäcker 11  
D-72135 Dettenhausen  
Tel.: +49 (0) 71 57/123-0  
Fax: +49 (0) 71 57/123-212  
E-Mail: [mail@graessner.de](mailto:mail@graessner.de)  
[www.graessner.de](http://www.graessner.de)

**Austria**

**GRAESSNER GmbH**  
Perfektastraße 61  
Objekt 6/2  
A-1230 Wien  
Tel.: +43 (1) 69924 30-0  
Fax: +43 (1) 69924 30-20  
E-Mail: [graessner@graessner.at](mailto:graessner@graessner.at)  
[www.graessner.at](http://www.graessner.at)

**France**

**MS-GRAESSNER GmbH & Co. KG**  
14, rue du Prêtreur  
F-67500 Haguenau  
Tel.: +33 (0) 3 88 86 06 48  
Mobil: +33 (0) 6 82 07 49 92  
E-Mail: [claude.rebmann@graessner.com](mailto:claude.rebmann@graessner.com)  
[www.graessner.com](http://www.graessner.com)

**Further information regarding the distribution network of MS-GRAESSNER can be found on: [www.graessner.com](http://www.graessner.com)**

## BEVEL GEAR



### Spiral, Hypoid and Zerol BevelGears

- Standard range and customised designs
- Module ms up to 0.5 to 12
- Diameters up to 410 mm
- Shaft angles from 10° to 170°
- More than 50 years of experience
- In-house gearing calculation
- We manufacture to your drawing or advise you of possible alternatives
- Ground gear teeth

## POWER GEAR



### The high performance bevel gearbox

- High torque, small size
- For medium input speeds
- Ratios  $i = 1:1$  up to 5:1
- Torques up to 7000 Nm
- Output via solid and hollow shaft
- Motor mounting either directly or via flange and coupling

## DYNA GEAR



### The highly dynamic servo right angle gearbox

- Hypoid gearing
- High input speeds at medium to high torques
- Ratios, **single-stage**  
 $i = 3:1$  bis 15:1
- Ratios, two-stage, up to 150:1
- Torques up to 1440 Nm
- Flexible motor mounting via flange and coupling
- Low backlash  $\leq 2$  arc min
- Variable ratios and uniform dimensions

## DYNA GEAR



### *Economy* The cost-effective servo right angle gearbox

- Hypoid gearing
- High input speeds at medium torques
- Ratios, **single-stage**,  
 $i = 5:1, 8:1, 10:1$  und 15:1
- Torques up to 1440 Nm
- Flexible motor mounting via flange and coupling
- Backlash  $\leq 6$  arc min
- Variable ratios and uniform dimensions

## DESIGN GEAR



### The customised gearbox

- Two-stage bevel helical gearbox with ratios up to  $i = 50:1$
- Single-stage gearboxes available as gear-change and reversing gearboxes
- Forced oil circulation lubrication system gearboxes for high speeds and torques
- Labyrinth sealed gearboxes with an efficiency of  $> 99\%$
- Special gearboxes with additional functional elements
- Endless possibilities, please ask

## PLANET GEAR



### The planetary gearbox

- Ratios, single-stage and two-stage  $i = 3:1$  bis 100:1 (higher ratios on request)
- Torques up to 540 Nm
- Flexible motor mounting via flange, with clamping or keyway
- Any installation position
- Economy or precision version