



GRAESSNER

MS-Graessner GmbH & Co. KG

THE GEAR COMPANY

BEVEL*G***EAR**

Competence and Performance

www.graessner.de

Gearing Precision and Performance

Almost no-one understands complex construction as well as MS-Graessner, due to the fact that the gear tooth and gear specialist's creations are based on more than 50 years of experience. Intelligent solutions for a wide range of sectors and applications make MS-Graessner a reliable industry partner in both gear tooth technology and gear construction.

Contents

Page

<i>Fundamentals of Bevel Gears</i>	4
<i>Production Capabilities</i>	5
<i>Examples of Applications</i>	6–7
<i>PowerGear Bevel Gear Dimensions</i>	8–13
<i>DynaGear Bevel Gear Dimensions</i>	14–17
<i>Tips for Assembly</i>	18
<i>Options</i>	19
<i>Lubrication</i>	20
<i>Order Information</i>	21

General

Advantages of Spiral, Hypoid and Zerol Bevel Gears

- High level of coverage due to the fact that several teeth are meshed simultaneously
- Resistant to elastic deformation of gears, shafts and bearings
- Circular arc gear teeth are more resistant to bending than straight and oblique gear teeth
- Very gentle transmission even at high-speed operation and under heavy load
- Noise and oscillation damped even at high peripheral speeds
- Gear sets can be assembled in your preferred direction of rotation
- > 97% efficiency depending upon layout and lubrication
- Due to convex tooth-loading the load is not concentrated on the tooth-ends
- All gear sets can be lapped in pairs upon request

	Spiral bevel gear	Hypoid bevel gear	Zerol® bevel gear
For transmitting forces at an angle of 90° or any other angle	■	■	■
At high torques	■	■	
At low torques			■
Under heavy load	■	■	■
Under light load	■	■	■
For low-noise operation	■	■	
For low-vibration transmission	■	■	
For drives that have input and output on the same level	■		■
For drives that have input and output axially offset		■	
For unusually high gear reduction		■	
If the pinion is to be as large as possible		■	
For all applications with space and weight limits	■	■	■

Spiral bevel gears
with circular arc teeth

Hypoid bevel gears
Similar to spiral bevel gears, but with the drive pinion axially offset either above or below. This means a greater pinion diameter, longer life and more gentle tooth meshing.

Zerol® bevel gears
Zerols are spiral bevel gears with a 0° central spiral angle, a combination of spiral- and straight-tooth bevel gears.

Tooth Contact Analysis

Tooth contact analysis for gear tooth limits with crowning, height crowning and flank twist.

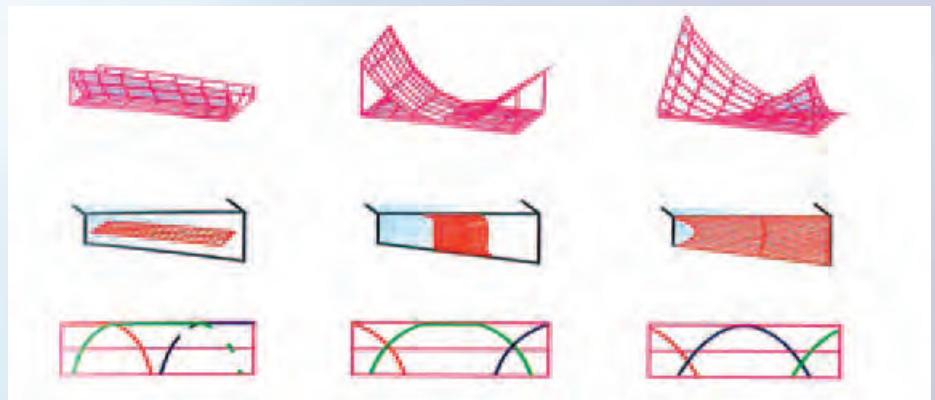

Source: Gleason
Zukunftsweisende
Kegelradverzahntechnik
Author: Hermann J. Stadtfeld

Our Production Capabilities

Milled gear tooth cutting

Gear tooth cutting quality ≤ 7 DIN 3965

	Module ms min.	Module ms max.	max. outer edge of gear \emptyset (A)	max. tooth width (B)	max. outer bevel distance	Shaft angle (B)	
						from	to
Spiral bevel gears	0,5	12,0	410 mm	66	280	10°	170°
Hypoid bevel gears	0,5	12,0	410 mm	66	280	-	-
Zerol® bevel gears	0,5	12,0	410 mm	66	280	10°	170°

(A) dependent on transmission ratio
(B) dependent on outer bevel distance

Ground gear tooth cutting

Gear tooth cutting quality ≤ 5 DIN 3965

	Module ms min.	Module ms max.	max. outer edge of gear \emptyset (A)	max. tooth width (B)	max. outer bevel distance	Shaft angle (B)	
						from	to
Spiral bevel gears	0,8	10,0	280 mm	66	280	10°	170°
Hypoid bevel gears	0,8	10,0	280 mm	66	280	-	-
Zerol® bevel gears	0,8	10,0	280 mm	66	280	10°	170°

(A) dependent on transmission ratio
(B) dependent on outer bevel distance

Advantages of Ground Gear Tooth Cutting

- Precise transmission
- Very quiet running
- Little heat generation
- Flexible options to optimise noise via influencing the tooth flank geometry
- Tooth grinding in accordance with the UMC process (Universal Motion Concept) in the case of applications where noise is of paramount importance

Gleason Tooth Grinding Machine



Examples of Applications



Optimum positioning of the tooth contact pattern is essential for a precise, low-noise bevel gear pairing.



Angular milling head with ground bevel gear set by MS-Graessner.

High-transmission hypoid gear set with typical shaft offset.





Spiral bevel gear pair with 45° shaft angle.

Customised gearboxes with 8:1 hypoid gear tooth ratio for extremely small spaces.

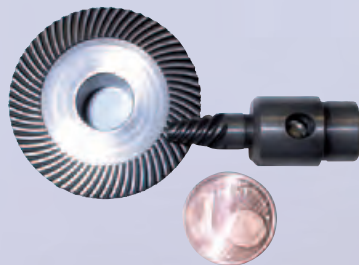
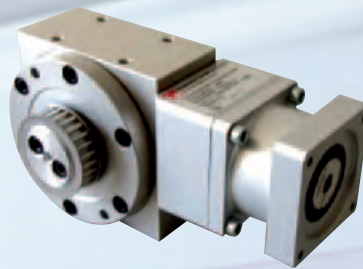

The smaller the bevel gear, the greater the know-how necessary.

Dimensions

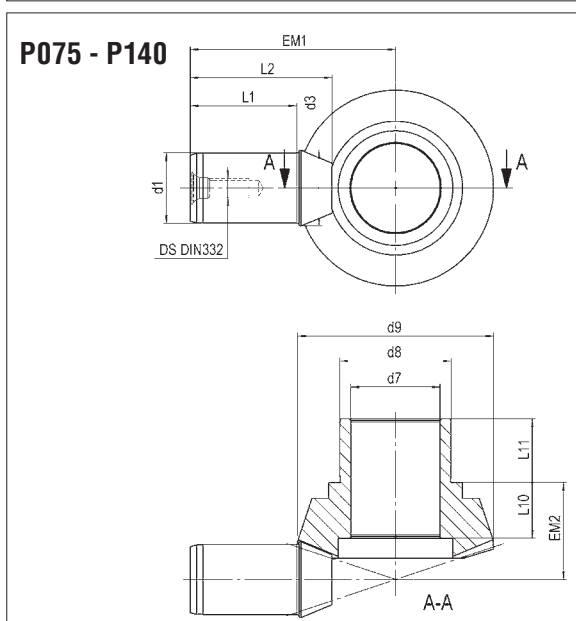
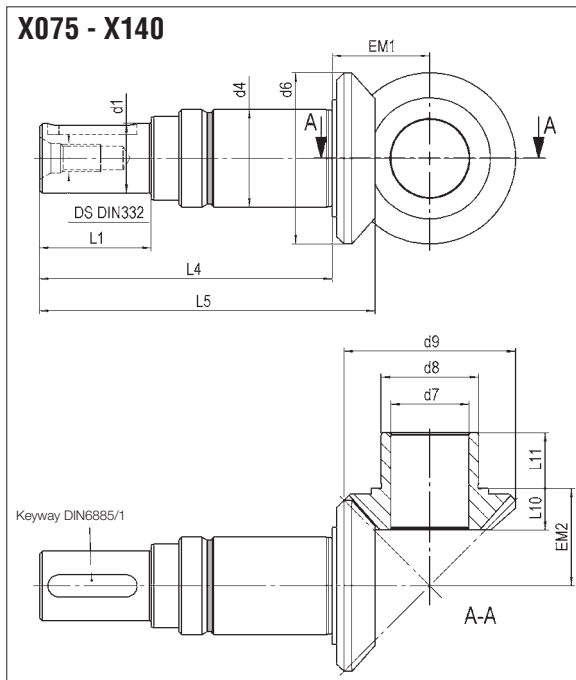
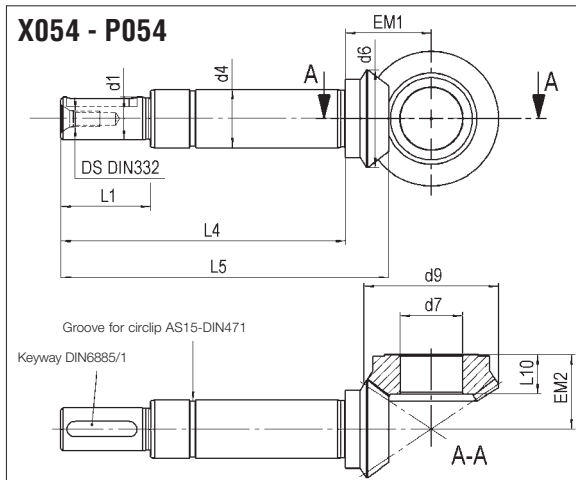

Gearbox size	i=	I.D.No.	M2nom	M2max	n1max	EM1
X054	1	21054S0141	24	36	4000	22
P054	1	21054S0111	15	23	6500	22
	1,5	21054S0311	15	23	6500	22
	2	21054S0511	12	18	6500	22
	3	21054S0711	12	18	6500	20,5

Gearbox size	i=	I.D.No.	M2nom	M2max	n1max	EM1
X075	1	21075S0141	87	131	3000	30
P075	1	21075S0111	45	68	6500	54,5
	1,5	21075S0311	45	68	6500	54,5
	2	21075S0511	42	63	6500	54,5
	3	21075S0711	33	50	6500	54,5
	4	21075S0911	28	42	6500	54,5
5	21075S1111	25	38	6500	54,5	

Gearbox size	i=	I.D.No.	M2nom	M2max	n1max	EM1
X090	1	21090S0141	135	203	2500	35
P090	1	21090S0111	78	117	5500	64,5
	1,5	21090S0311	78	117	5500	64,5
	2	21090S0511	68	102	5500	64,5
	3	21090S0711	54	81	5500	64,5
	4	21090S0911	52	78	5500	64,5
5	21090S1111	40	60	5500	64,5	

Gearbox size	i=	I.D.No.	M2nom	M2max	n1max	EM1
X110	1	21110S0141	290	435	2000	44,5
P110	1	21110S0111	150	225	4500	79,5
	1,5	21110S0311	150	225	4500	79,5
	2	21110S0511	150	225	4500	79,5
	3	21110S0711	120	180	4500	79,5
	4	21110S0911	100	150	4500	79,5
5	21110S1111	85	128	4500	79,5	

Gearbox size	i=	I.D.No.	M2nom	M2max	n1max	EM1
X140	1	21140S0141	625	938	2000	59
P140	1	21140S0111	360	540	3500	114,5
	1,5	21140S0311	360	540	3500	114,5
	2	21140S0511	330	495	3500	114,5
	3	21140S0711	270	405	3500	114,5
	4	21140S0911	224	336	3500	114,5
5	21140S1111	196	294	3500	114,5	

M [Nm], n [min⁻¹], all other measurements in mm.

	d1	d4	d6	L4	L5	EM2	d7	d8	d9	L10	L11
	14	15	34,5	80	90,19	19	16		34,5	8,5	
	11	15	34,5	73	83,19	19	16		34,5	8,5	
	11	15	25	73	84,09	19	16		34,5	10	
	11	15	19,5	73	83,95	19	16		34,5	10	
	11	15	16,5	74,5	84,12	19	16		34,5	10	

	d1	d4	d6	L4	L5	EM2	d7	d8	d9	L10	L11
	20	25	51,5	95	108,79	30	22	28	51,5	14	18,5
	d1	d4	d3	L1	L2	EM2	d7	d8	d9	L10	L11
	19		45,38	27,3	40	25	22	28	44	10	18
	19		36,99	27,3	38,18	25	22	28	51,5	14	18
	19		28,58	27,3	38,21	25	22	28	51,5	14	18
	19		19	30,6	38,08	25	22	28	51,5	14	18
	19		<19	23,89	37,72	25	22	28	51,5	14	18
	19		<19	22,8	37,74	25	22	28	51,5	14	18
	d1	d4	d6	L4	L5	EM2	d7	d8	d9	L10	L11
	25	35	61,5	105	120,36	35	28	35	61,5	15	20
	d1	d4	d3	L1	L2	EM2	d7	d8	d9	L10	L11
	22		55,02	32,3	47	30,5	28	35	53	12	20
	22		44,35	32,3	44,97	30,5	28	35	61,5	17,5	20
	22		34,29	32,3	44,66	30,5	28	35	61,5	17,5	20
	22		<24	33,46	44,57	30,5	28	35	61,5	17,5	20
	22		<22	28,81	44,71	30,5	28	35	61,5	17,5	20
	22		<21	27,64	44,75	30,5	28	35	61,5	17,5	20
	d1	d4	d6	L4	L5	EM2	d7	d8	d9	L10	L11
	35	45	79,5	130,5	149,77	45	42	50	79,5	19	23
	d1	d4	d3	L1	L2	EM2	d7	d8	d9	L10	L11
	28		68,43	37,8	57	37,5	38	45	66	14,5	22,5
	28		57,52	37,8	54,09	37,5	38	45	79,5	20,5	22,5
	28		44,29	37,8	53,87	37,5	38	45	79,5	20,5	22,5
	28		31	39,42	53,94	37,5	38	45	79,5	20,5	22,5
	28		<28	34,15	53,63	37,5	38	45	79,5	20,5	22,5
	28		<28	32,12	53,75	37,5	38	45	79,5	20,5	22,5
	d1	d4	d6	L4	L5	EM2	d7	d8	d9	L10	L11
	40	50	104,5	156	181,87	60	55	65	104,5	26	26
	d1	d4	d3	L1	L2	EM2	d7	d8	d9	L10	L11
	32		91,22	60,3	86	49	50	60	88	19	25
	32		75,63	60,3	81,11	49	50	60	104,5	26	25
	32		58,59	60,3	80,72	49	50	60	104,5	26	25
	32		<35	61,18	80,84	49	50	60	104,5	26	25
	32		<32	57,87	80,65	49	50	60	104,5	26	25
	32		<32	52,45	80,75	49	50	60	104,5	26	25

Dimensions

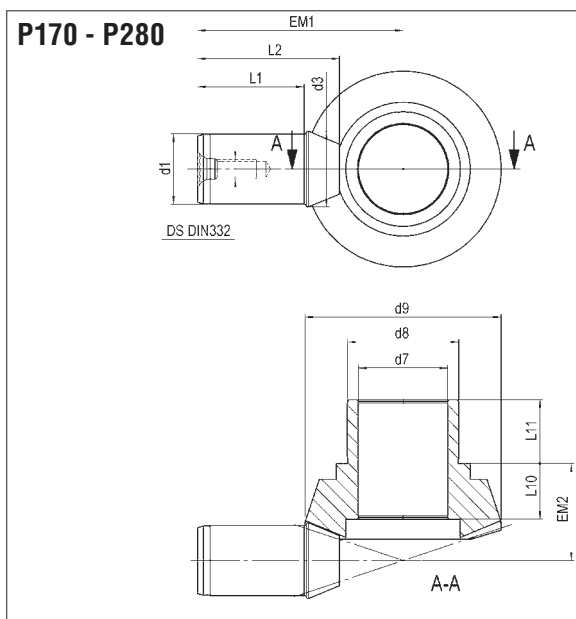
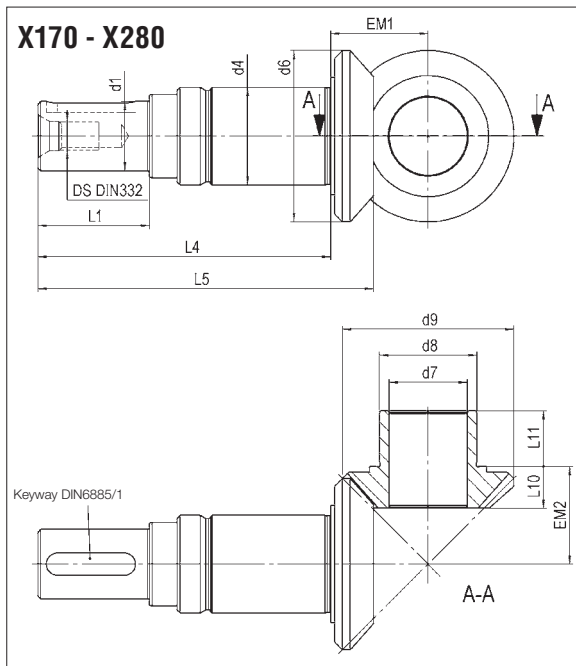

Gearbox size	i=	I.D.No.	M2nom	M2max	n1max	EM1
X170	1	21170S0141	1020	1530	1500	70
		I.D.No.	M2nom	M2max	n1max	EM1
P170	1	21170S0111	585	878	3000	129
	1,5	21170S0311	585	878	3000	129
	2	21170S0511	544	816	3000	129
	3	21170S0711	450	675	3000	129
	4	21170S0911	376	564	3000	129
	5	21170S1111	320	480	3000	129
Gearbox size	i=	I.D.No.	M2nom	M2max	n1max	EM1
X210	1	21110S0141	2050	3075	1200	92
		I.D.No.	M2nom	M2max	n1max	EM1
P210	1	21210S0111	1300	1950	2200	157
	1,5	21210S0311	1300	1950	2200	157
	2	21210S0511	1220	1830	2200	157
	3	21210S0711	1020	1530	2200	157
	4	21210S0911	860	1290	2200	157
	5	21210S1111	740	1110	2200	157
Gearbox size	i=	I.D.No.	M2nom	M2max	n1max	EM1
X240	1	21240S0141	3350	5025	1200	109
		I.D.No.	M2nom	M2max	n1max	EM1
P240	1	21240S0111	2150	3225	2000	182
	1,5	21240S0311	2150	3225	2000	182
	2	21240S0511	2010	3015	2000	182
	3	21240S0711	1650	2475	2000	182
	4	21240S0911	1410	2115	2000	182
	5	21240S1111	1210	1815	2000	182
Gearbox size	i=	I.D.No.	M2nom	M2max	n1max	EM1
X280	1	21280S0141	5200	7800	1000	128
		I.D.No.	M2nom	M2max	n1max	EM1
P280	1	21280S0111	3200	4800	1700	209
	1,5	21280S0311	3200	4800	1700	209
	2	21280S0511	3050	4575	1700	209
	3	21280S0711	2850	4275	1700	209
	4	21280S0911	2300	3450	1700	209
	5	21280S1111	2000	3000	1700	209

M [Nm], n [min⁻¹], all other measurements in mm.

	d1	d4	d6	L4	L5	EM2	d7	d8	d9	L10	L11
	50	60	124,5	185	215,41	74	65	75	124,5	34	29
	d1	d4	d3	L1	L2	EM2	d7	d8	d9	L10	L11
	38		108,74	64,3	95,5	59	60	70	104,5	23	28
	38		90,38	64,3	89,12	59	60	70	124,5	32	28
	38		70,1	64,3	89,37	59	60	70	124,5	32	28
	38		<40	65,58	88,86	86	60	70	124,5	32	28
	38		<38	63,77	88,58	59	60	70	124,5	32	28
	38		<38	56,5	88,73	59	60	70	124,5	32	28
	d1	d4	d6	L4	L5	EM2	d7	d8	d9	L10	L11
	60	75	164,5	228	267,53	91	80	100	164,5	39	37
	d1	d4	d3	L1	L2	EM2	d7	d8	d9	L10	L11
	50		143,9	71,3	114	76	75	90	138	29	36
	50		119,6	71,3	105,07	76	75	90	164,5	40	36
	50		92,7	71,3	104,03	76	75	90	164,5	40	36
	50		63,2	73,41	104,21	76	75	90	164,5	40	36
	50		<50	71,19	103,52	76	75	90	164,5	40	36
	50		<50	63,52	103,76	76	75	90	164,5	40	36
	d1	d4	d6	L4	L5	EM2	d7	d8	d9	L10	L11
	70	85	194,5	251	298,77	106	90	110	194,5	48	40
	d1	d4	d3	L1	L2	EM2	d7	d8	d9	L10	L11
	60		170,1	80,3	131,05	90	85	105	162	34	38
	60		141,8	80,3	120,33	90	85	105	194,5	49	38
	60		109,7	80,3	119,31	90	85	105	194,5	49	38
	60		<70	83,39	119,12	90	85	105	194,5	49	38
	60		<60	78,44	118,54	90	85	105	194,5	49	38
	60		<60	63,91	118,78	90	85	105	194,5	49	38
	d1	d4	d6	L4	L5	EM2	d7	d8	d9	L10	L11
	80	95	229,5	297	352,34	125	100	130	229,5	57	47
	d1	d4	d3	L1	L2	EM2	d7	d8	d9	L10	L11
	70		200,3	89,3	148,98	106	95	120	193	40	42
	70		166,7	89,3	137,11	106	95	120	229,5	59	42
	70		130,1	89,3	135,06	106	95	120	229,5	59	42
	70		89,91	92,62	135,38	106	95	120	229,5	59	42
	70		<70	87,71	134,1	106	95	120	229,5	59	42
	70		<70	73,62	134,28	106	95	120	229,5	59	42

PowerGear bevel gears

Dimensions

BEVEL GEAR

P360 + P450
i= 1:1 + 1,5:1

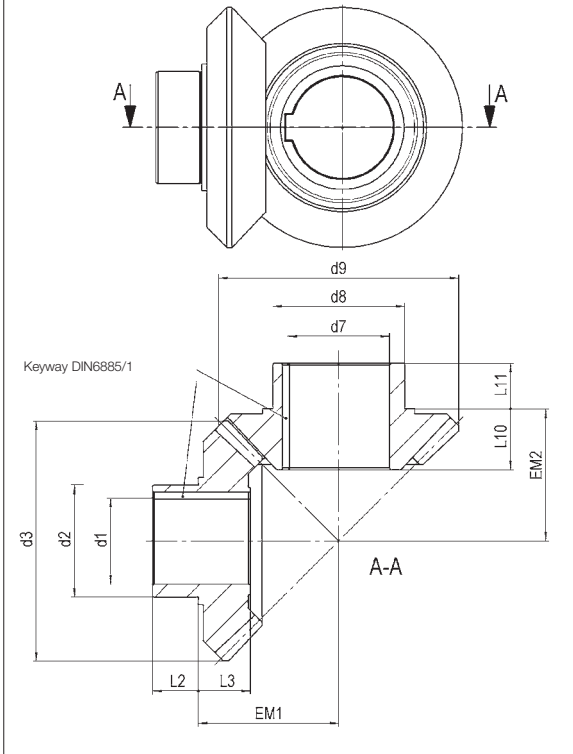

Gearbox size	i=	I.D.No.	M2nom	M2max	n1max	EM1
P360	1	21360S0111	5300	7950	1400	138
	1,5	21360S0311	5300	7950	1400	138
		I.D.No.	M2nom	M2max	n1max	EM1
	2	21360S0511	5300	7950	1400	138
	3	I.D.No.	M2nom	M2max	n1max	EM1
21360S0711		5300	7950	1400	155,5	
4		21360S0911	4500	6750	1400	152
5	21360S1111	3800	5700	1400	150	

P360 + P450
i= 3:1 - 5:1

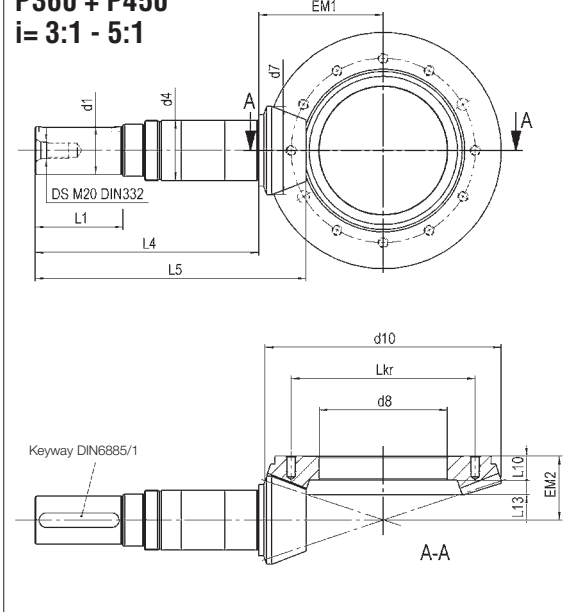

Gearbox size	i=	I.D.No.	M2nom	M2max	n1max	EM1
P450	1	21450S0111	9300	13950	1100	184
	1,5	21450S0311	9300	13950	1100	184
		I.D.No.	M2nom	M2max	n1max	EM1
	2	21450S0511	9300	13950	1100	184
	3	I.D.No.	M2nom	M2max	n1max	EM1
21450S0711		9300	13950	1100	200	
4		21450S0911	9300	13950	1100	200
5	21450S1111	7800	11700	1100	195	

M [Nm], n [min⁻¹], all other measurements in mm.

	d1	d2	d3		L2	L3	EM2	d7	d8	d9	L10	L11
	85	110	236		45	51	130	100	130	236	60	45
	85	110	182		45	51	130	100	130	258	60	45
	d1	d4	d7		L4	L5	EM2	d8	d9	d10	L11	L12
	75	85	145		307	359,19	130	100	130	268,5	60	45
	d1	d4	d7	L1	L4	L5	EM2	d8	Lkr	d10	L10	L13
	60	75	110	110	279,5	338,6	80	160	230	295	30	18,09
	55	75	88,5	85	279,5	312,25	80	160	230	295	30	26,04
	50	60	74,5	80	258	307,52	80	160	230	295	30	31,11

	d1	d2	d3		L2	L3	EM2	d7	d8	d9	L10	L11
	100	130	305		54	74	169	120	160	305	84	51
	100	130	239		54	74	169	120	160	336	84	51
	d1	d4	d7		L4	L5	EM2	d8	d9	d10	L11	L12
	90	100	190		386	460,2	169	120	160	346	84	51
	d1	d4	d7	L1	L4	L5	EM2	d8	Lkr	d10	L10	L13
	75	85	145	120	330	404	110	175	300	383	40	28,58
	70	85	114	120	330	403,85	110	175	300	384	40	39,29
	60	70	<90	110	325	392,01	110	175	300	385	40	45,34

Dimensions

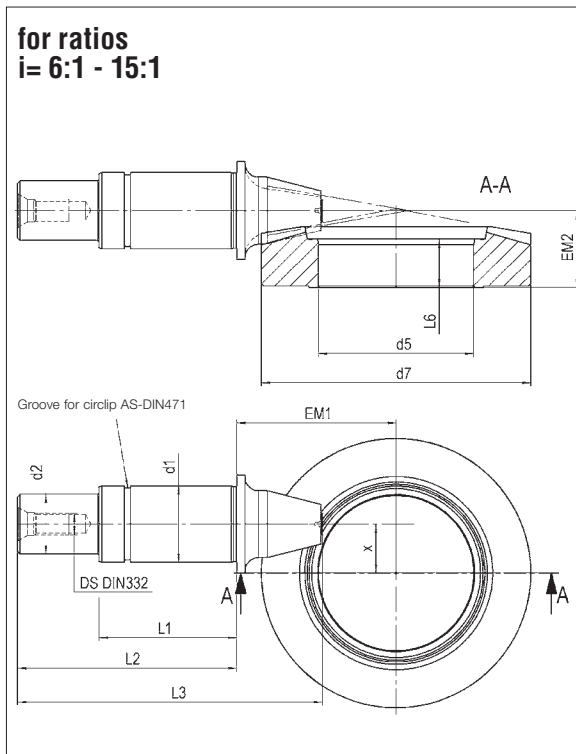
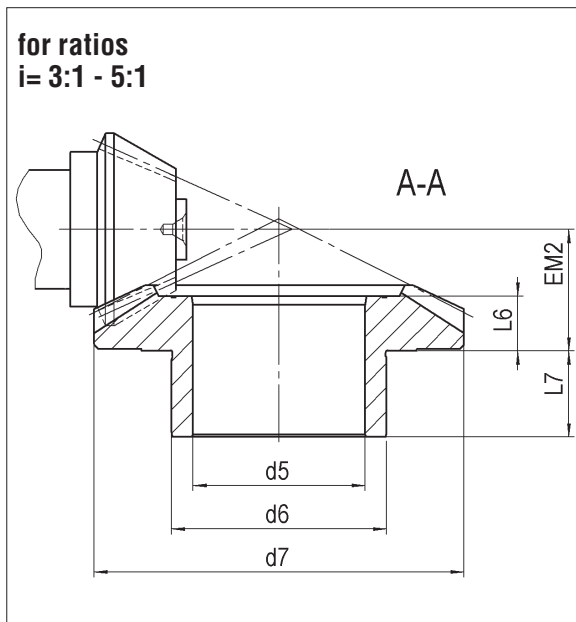

Gearbox size	$i =$	I.D.No.	M2nom	M2max	n1nom	x (offset)
D55	3	22055H10701	35	53	6000	9
	4	22055H10901	35	53	6000	9
	5	22055H11101	35	53	6000	9
	6	22055H12001	35	53	6000	9
	8	22055H12401	35	53	6000	9
	10	22055H12801	35	53	6000	9
	12	22055H14001	25	38	6000	9
15	22055H14301	25	38	6000	9	
D75	3	22075H10701	70	105	6000	14
	4	22075H10901	70	105	6000	14
	5	22075H11101	70	105	6000	14
	6	22075H12001	70	105	6000	14
	8	22075H12401	70	105	6000	14
	10	22075H12801	70	105	6000	14
	12	22075H14001	50	75	6000	14
15	22075H14301	50	75	6000	14	
D90	3	22090H10701	140	210	5000	18
	4	22090H10901	140	210	5000	18
	5	22090H11101	140	210	5000	18
	6	22090H12001	140	210	5000	18
	8	22090H12401	140	210	5000	18
	10	22090H12801	140	210	5000	18
	12	22090H14001	95	143	5000	18
15	22090H14301	85	143	5000	18	
D115	3	22115H10701	260	390	4000	23
	4	22115H10901	260	390	4000	23
	5	22115H11101	260	390	4000	23
	6	22115H12001	260	390	4000	23
	8	22115H12401	260	390	4000	23
	10	22115H12801	260	390	4000	23
	12	22115H14001	180	270	4000	23
15	22115H14301	180	270	4000	23	
D130	3	22130H10701	430	645	3000	27
	4	22130H10901	430	645	3000	27
	5	22130H11101	430	645	3000	27
	6	22130H12001	430	645	3000	27
	8	22130H12401	430	645	3000	27
	10	22130H12801	430	645	3000	27
	12	22130H14001	300	450	3000	27
15	22130H14301	300	450	3000	27	

M [Nm], n [min⁻¹], all other measurements in mm.

	EM1	L1	L2	L3	d1	d2	EM2	L6	L7	d5	d6	d7
	35	51	66	84	17	14	17	7,5	18	30	35	60,5
	35	51	66	84	17	14	17	7,5	18	30	35	60,5
	35	51	66	84	17	14	17	7,5	18	30	35	60,5
	40	46	61	80,3	17	14	17,75	10,8		37		69,5
	40	46	61	80,3	17	14	17,75	10,8		37		69,5
	40	46	61	80,3	17	14	17,75	10,8		37		69,5
	40	46	61	80,3	17	14	17,75	10,8		37		69,5
	40	46	61	79,68	17	14	17,75	10,8		37		69,5
	41	57	82	104	22	18	20,5	8,5	20	35	45	72,5
	41	57	82	104	22	18	20,5	8,5	20	35	45	72,5
	41	57	82	104	22	18	20,5	8,5	20	35	45	72,5
	47	51	76	100,5	22	18	20,5	12,5		45		81
	47	51	76	100,5	22	18	20,5	12,5		45		81
	47	51	76	100,5	22	18	20,5	12,5		45		81
	47	51	76	100,5	22	18	20,5	12,5		45		81
	47	51	76	99,77	22	18	20,5	12,5		45		81
	48,5	60,5	90,5	117,5	28	22	28,25	12,75	20	40	50	86
	48,5	60,5	90,5	117,5	28	22	28,25	12,75	20	40	50	86
	48,5	60,5	90,5	117,11	28	22	28,25	12,75	20	40	50	86
	58,5	50,5	80,5	112	28	22	28,25	17,75		57		99
	58,5	50,5	80,5	112	28	22	28,25	17,75		57		99
	58,5	50,5	80,5	112	28	22	28,25	17,75		57		99
	58,5	50,5	80,5	112	28	22	28,25	17,75		57		99
	58,5	50,5	80,5	111,2	28	22	28,25	17,75		57		99
	59	66	101	133,5	35	28	33	14	25	60	70	105,5
	59	66	101	133,5	35	28	33	14	25	60	70	105,5
	59	66	101	133,5	35	28	33	14	25	60	70	105,5
	69	56	91	129,5	35	28	34,25	22,25		68		119
	69	56	91	129,5	35	28	34,25	22,25		68		119
	69	56	91	129,5	35	28	34,25	22,25		68		119
	69	56	91	129,5	35	28	34,25	22,25		68		119
	69	56	91	128,86	35	28	34,25	22,25		68		119
	69	72	108	144,5	40	32	37,5	16	28,5	65	80	128
	69	72	108	144,5	40	32	37,5	16	28,5	65	80	128
	69	72	108	144,5	40	32	37,5	16	28,5	65	80	128
	81	60	96	141,5	40	32	40,25	25,75		75		141,5
	81	60	96	141,5	40	32	40,25	25,75		75		141,5
	81	60	96	141,5	40	32	40,25	25,75		75		141,5
	81	60	96	141,5	40	32	40,25	25,75		75		141,5
	81	60	96	141,69	40	32	40,25	25,75		75		141,5

Dimensions

for ratios
 $i = 3:1 - 5:1$

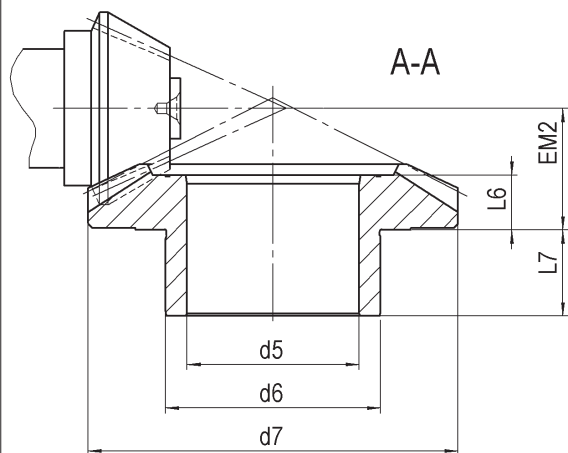

for ratios
 $i = 6:1 - 15:1$

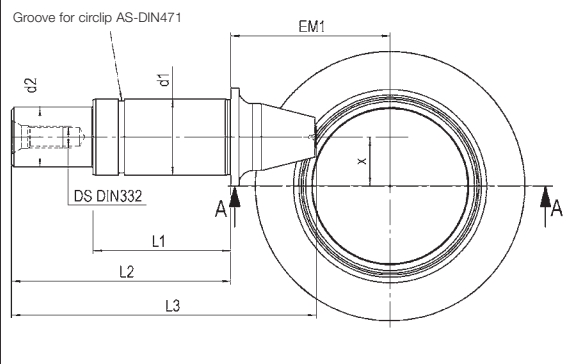
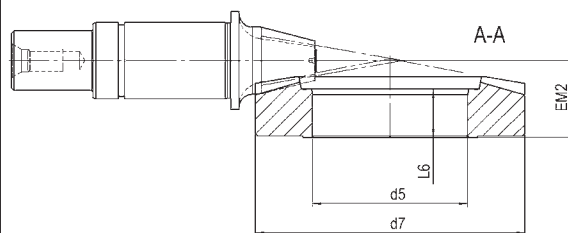

Gearbox size	$i =$	I.D.No.	M2nom	M2max	n1nom	x (offset)
D140	3	22140H10701	720	1080	3000	32
	4	22140H10901	720	1080	3000	32
	5	22140H11101	720	1080	3000	32
	6	22140H12001	720	1080	3000	32
	8	22140H12401	720	1080	3000	32
	10	22140H12801	720	1080	3000	32
	12	22140H14001	510	765	3000	32
15	22140H14301	510	765	3000	32	
D160	3	22160H10701	1100	1650	2500	38
	4	22160H10901	1100	1650	2500	38
	5	22160H11101	1100	1650	2500	38
	6	22160H12001	1100	1650	2500	38
	8	22160H12401	1100	1650	2500	38
	10	22160H12801	1100	1650	2500	38
	12	22160H14001	815	1223	2500	38
15	22160H14301	815	1223	2500	38	
D190	3	22190H10701	1440	2160	2500	42
	4	22190H10901	1440	2160	2500	42
	5	22190H11101	1440	2160	2500	42
	6	22190H12001	1440	2160	2500	42
	8	22190H12401	1440	2160	2500	42
	10	22190H12801	1440	2160	2500	42
	12	22190H14001	1020	1530	2500	42
15	22190H14301	1020	1530	2500	42	

M [Nm], n [min^{-1}], all other measurements in mm.

	EM1	L1	L2	L3	d1	d2	EM2	L6	L7	d5	d6	d7
	81	78	116	160	45	32	45	21	22,5	80	100	147,5
	81	78	116	160	45	32	45	21	22,5	80	100	147,5
	81	78	116	160	45	32	45	21	22,5	80	100	147,5
	96	63	101	157	45	32	40,75	23,75		92		164
	96	63	101	157	45	32	40,75	23,75		92		164
	96	63	101	157	45	32	40,75	23,75		92		164
	96	63	101	157	45	32	40,75	23,75		92		164
	96	63	101	155,75	45	32	40,75	23,75		92		164
	93	82	124	178	50	36	53,5	27,5	27	90	120	167
	93	82	124	178	50	36	53,5	27,5	27	90	120	167
	93	82	124	178	50	36	53,5	27,5	27	90	120	167
	109	66	108	169,5	50	36	48	29		105		189,5
	109	66	108	169,5	50	36	48	29		105		189,5
	109	66	108	169,5	50	36	48	29		105		189,5
	109	66	108	169,5	50	36	48	29		105		189,5
	109	66	108	168,38	50	36	48	29		105		189,5
	106	85	130	189	55	40	56	28	38	100	120	191,5
	106	85	130	189	55	40	56	28	38	100	120	191,5
	106	85	130	189	55	40	56	28	38	100	120	191,5
	123	68	113	181	55	40	57	36		116		214
	123	68	113	181	55	40	57	36		116		214
	123	68	113	181	55	40	57	36		116		214
	123	68	113	181	55	40	57	36		116		214
	123	68	113	180,03	55	40	57	36		116		214

Tips for Assembly

- The housing and all components must be cleaned.
- Attention should be paid to the bearing manufacturer's guidelines when assembling the rolling bearings
- Lapped gears must be assembled in pairs.
- The radial and axial contact surfaces should be inspected for radial and axial runout.
- The pinion should be assembled at the correct distance.
- The gear should be assembled with the recommended flank play.
- The pinion and gear must be secured against axial thrust in both directions.
- The tooth contact pattern should be inspected.
- Care should be taken that the toothed gears and bearings are sufficiently lubricated.

Services

Gear repairs

- Damage assessment and diagnosis
- In-house repairs
- Repairs on clients' premises

Gear inspection

- Inspection
- Maintenance
- Life-span maintenance inspections on clients' premises

Replacement parts

- Seal kits, bearing sets, bevel gears, shafts, lubricants

Tools

- Assembly and disassembly tools by industry for industry

Training

- Fit for repairs
- Disassembly and assembly
- Recognition and assessment of damage
- Communication of settings data
- Assessment and correction of tooth contact pattern

Advice

- Answers to all questions surrounding gears and their implementation
- Information and assistance on finding gears and replacement parts

Assistance in emergency situations of gear malfunction or machine downtime!

Tel. +49 (0)71 57/123-140, -141

Fax +49 (0)71 57/123-220

emergency@graessner.de

Layout, evaluation and tooth contact pattern development for bevel gears in accordance with Gleason

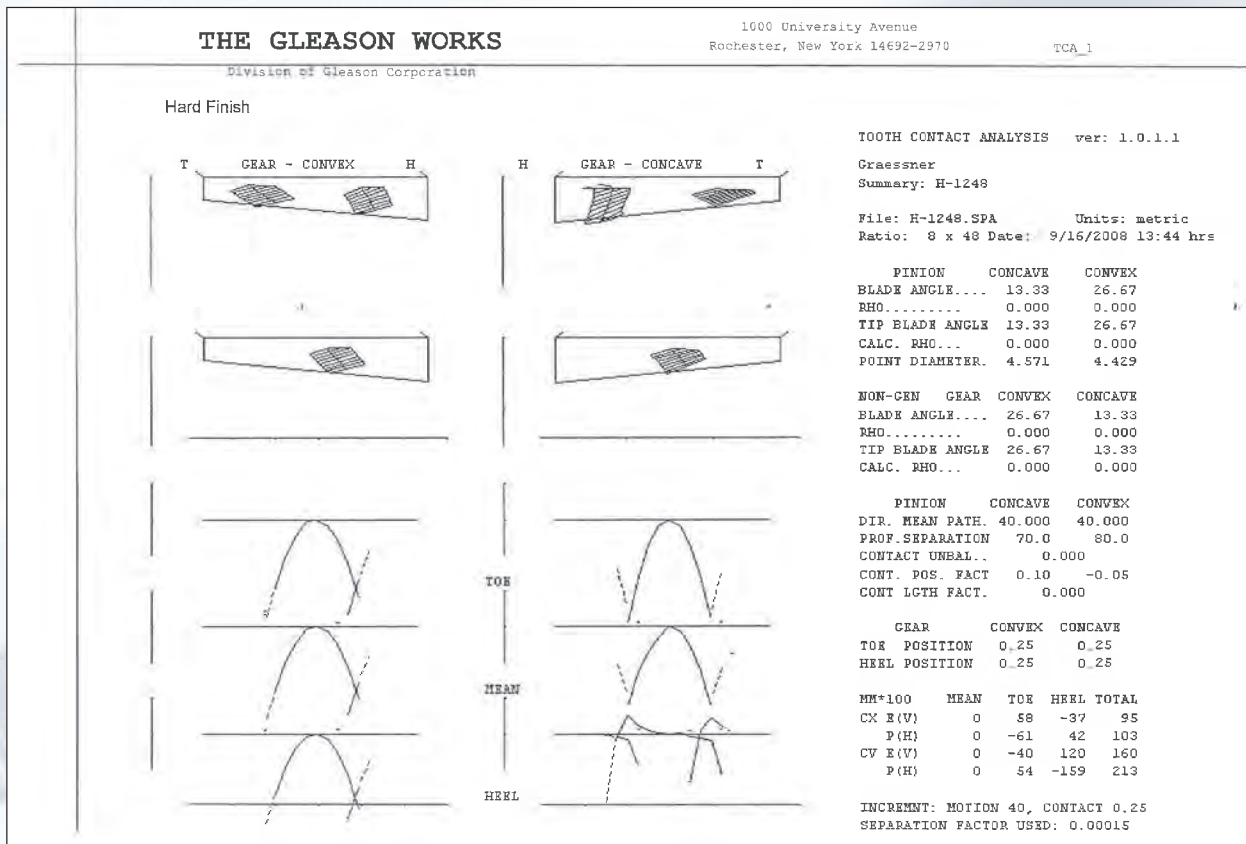

Stability

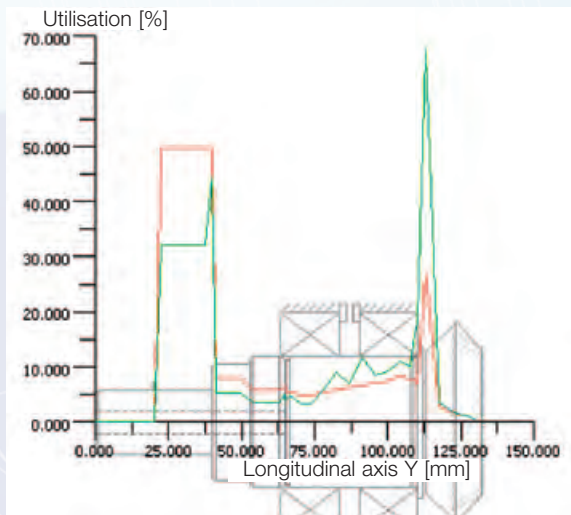

Layout of a complete drive

Evaluation via the Kisssoft

program for calculation, layout and optimisation of machine parts, such as toothed gears, shafts and bearings, screws, springs, joining elements and belts



■ Additional gear tooth parts are available upon request. Please contact us!

Lubricant table

Lubricant:	Speed range up to / over min ⁻¹	Viscosity ISO VG DIN 51519 at 40 °C (mm ² /s)	Brand				
			Aral	Castrol performance	Mobil	Shell	
Mineral oils	500	VG 220	Degol BG 220 Plus	Optigear BM 220 Tribol 1100/220	Mobilgear 600 XP 220	Shell Omala F220 Shell Omala 220	
	1000	VG 150	Degol BG 150 Plus	Optigear BM 150 Tribol 1100/150	Mobilgear 600 XP 150	Shell Omala F150 Shell Omala 150	
	1500	VG 100	Degol BG 100 Plus	Optigear BM 100 Tribol 1100/100	Mobilgear 600 XP 100	Shell Omala F100 Shell Omala 100	
	over 2000	VG 68	Degol BG 68 Plus		Mobilgear 600 XP 68	Shell Omala 68	
Mineral oils for hypoid drives	up to 2000	SAE class 85W-90			Mobilube GX 85W-90		
	over 2000	SAE class 80W			Mobilube GX 80W-A		
Polyglycols (PG oil)	500	VG 220	Degol GS 220	Tribol 800/220	Mobil Glygoyle 30	Shell Tivela S 220 Shell Cassida WG 220	
	1000	VG 150	Degol GS 150	Tribol 800/150	Mobil Glygoyle 22	Shell Tivela S150 Shell Cassida WG 150	
	from 2000	VG 100		Tribol 800/100	Mobil Glygoyle 11 (VG 85)		
Poly-a-olefins (PAO oil)	500	VG 220	Degol PAS 220	Optigear Synth. A220 Alphasyn EP 220	Mobil SHC 630 Mobil SHC Gear 220	Shell Omala HD220	
	1000 (3000)	VG 150	Degol PAS 150	Alphasyn EP 150	Mobil SHC 629 Mobil SHC Gear 150	Shell Omala HD150	
	1500	VG 100			Mobil SHC 627		
	from 1500	VG 68			Mobil SHC 626		
Physiologically non-hazardous oils (PHY oil) USDA -H1 Certification			Aral	Castrol performance	Mobil	Shell	Klüber
	1000	VG 220	Aral Eural Gear 220	Optileb GT 220 Tribol FoodProof 1800/220	Mobil DTE FM 220	Shell Cassida WG 220	*Klüberoil 4 UH1 – 220 N **Klübersynth UH1 6-220
	1500	VG 150	Aral Eural Gear 150	Optileb GT 150	Mobil DTE FM 150		*Klüberoil 4 UH1 – 150 **Klübersynth UH1 6-150
	from 1500	VG 100	Aral Eural Gear 68	Optileb GT 100			*Klüberoil 4 UH1 - 68 N

* Synth. KW oil, Ester oil

** Polyglykol oil

Order example

a) Standard bevel gear pairs according to the catalogue

I.D. No.	-	Bevel gear	-	P	-	090	-	1,00:1
<u>1.</u>		<u>2.</u>		<u>3.</u>		<u>4.</u>		<u>5.</u>

- 1. I.D. No.** *s. pages 8-17*
- 2. Bevel gear pair**
- 3. P = PowerGear**
D = DynaGear
- 4. Gearbox size** *s. pages 8-17*
- 5. Ratio** *s. pages 8-17*

b) Customised gear pairs

The following information is necessary:

- * **Max. outer diameter in mm**
- * **Ratio**
- * **Material**
- * **Gear tooth cutting quality ≤ 7 or ≤ 5**
- * **Torque in Nm**
- * **Options**
- * **Illustration**



Germany

MS-GRAESSNER GmbH & Co. KG
THE GEAR COMPANY
Kuchenäcker 11
D-72135 Dettenhausen
Tel.: +49 (0) 71 57/123-0
Fax: +49 (0) 71 57/123-212
E-Mail: mail@graessner.de
www.graessner.de

Austria

GRAESSNER GmbH
Perfektastraße 61
Objekt 6/2
A-1230 Wien
Tel.: +43 (1) 6992430-0
Fax: +43 (1) 6992430-20
E-Mail: graessner@graessner.at
www.graessner.at

You can find more information on the MS-GRAESSNER international sales network at: www.graessner.com

BEVEL GEAR



Spiral, hypoid and Zerol bevel gears

- Standard range and customised designs
- Modul ms from 0,5 to 12
- Diameters up to 410 mm
- Shaft angle from 10° to 170°
- More than 50 years' experience
- In-house gearing measurement
- We manufacture according to your drawing or consult you with on possible alternatives
- Tooth flanks - ground gear teeth

POWER GEAR



High torque right angle gearboxes

- Highest torque within small gearbox size
- For medium input speed
- Ratios $i = 1:1$ up to $5:1$
- Torque values up to 7000 Nm
- Output via solid and hollow shaft
- Motor mounting either directly or via flange and coupling

DYNA GEAR



High dynamic right angle servo gearboxes

- Hypoid gearing
- High input speed at medium and high torque
- Ratios: single-stage $i = 3:1$ up to $15:1$
- Two-stage up to $150:1$
- Torque values up to 1440 Nm
- Flexible motor mounting via flange and coupling
- Low backlash ≤ 2 arcmin
- Variable ratios within one gearbox size

DYNA GEAR



***Economy* Cost-optimised right angle servo gearboxes**

- Hypoid gearing
- High input speed at medium torque
- Ratios $i = 5:1, 8:1, 10:1$ and $15:1$, all single-stage
- Torque values up to 140 Nm
- Flexible motor mounting via flange and coupling
- Backlash ≤ 6 arcmin
- Variable ratios within one gearbox size

DESIGN GEAR

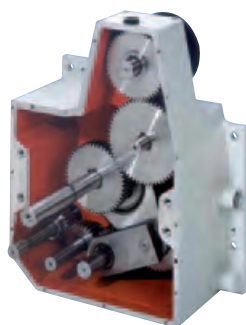

Customised gearboxes

- Two-stage helical bevel gearboxes with ratios of up to $i = 50:1$
- Single-stage gearboxes available as gear change and reversing gearboxes
- Forced oil circulation lubrication for high speeds and torques
- Labyrinth sealed gearboxes with an efficiency of $> 99\%$
- Special gearboxes with additional functional elements
- Wide range of options upon request

DYNA GEAR

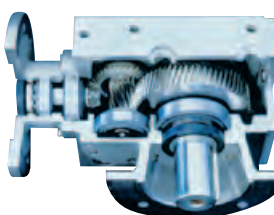

***Precision* Helical bevel gearboxes**

- Ratios, two-stage, up to $i = 50:1$
- Nominal torque up to 7500 Nm
- Backlash < 5 arcmin
- Universal mounting position
- Extremely compact design