

POWER ***GEAR***

*The high performance
bevel gearbox*

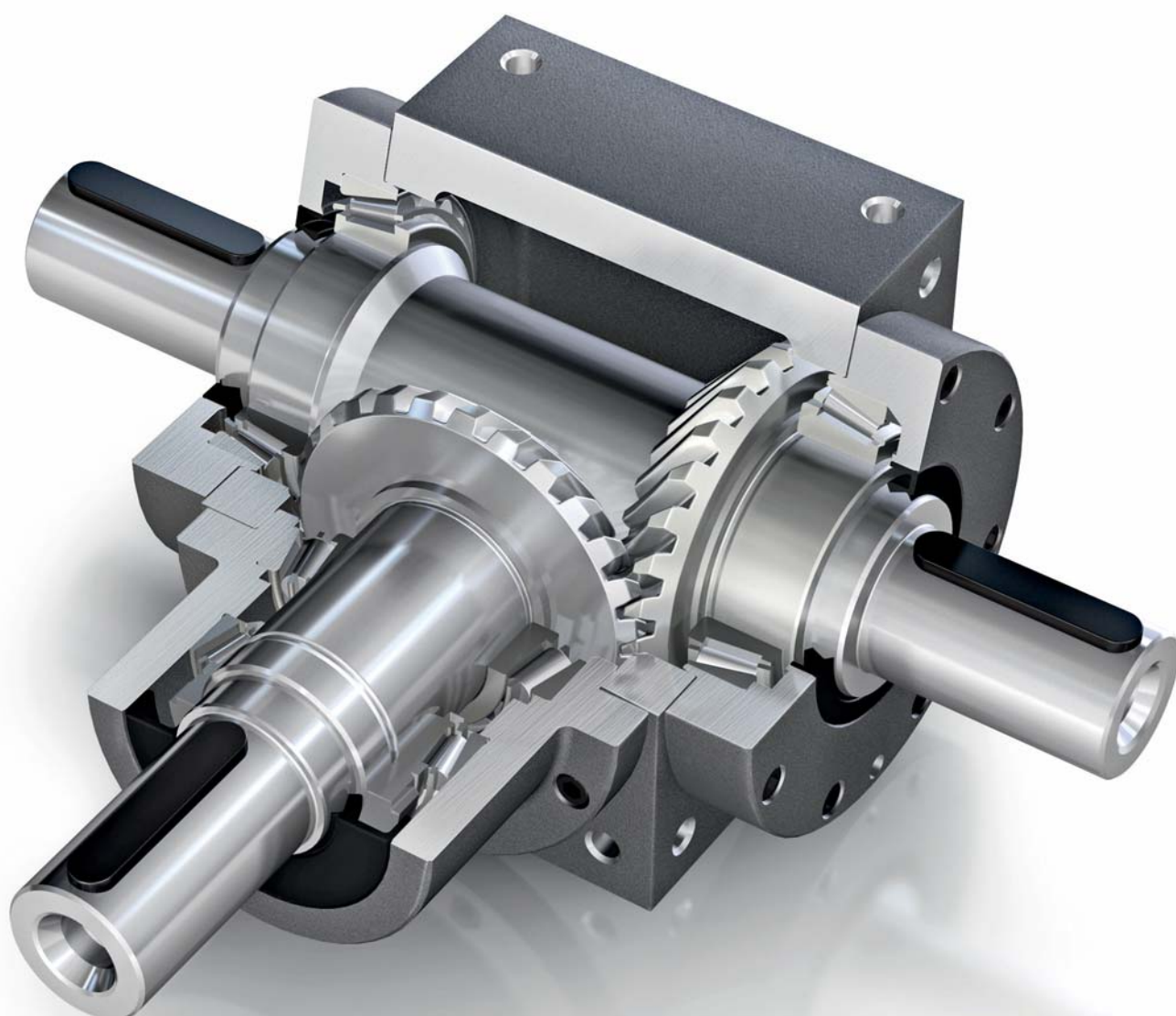

A close-up, high-angle photograph of a bevel gear assembly. The image shows the intricate teeth of the gears, which are metallic and highly polished. The lighting creates strong highlights and shadows, emphasizing the three-dimensional structure of the gear teeth. A semi-transparent white rectangular box is overlaid on the upper portion of the image, containing text.

Precision combines with performance.

Bevel gear technology is at the heart of an assembly consisting of gear housing, shafts, flanges and bearings resulting in a high performance gearbox. With over 60 years of experience, MS-GRAESSNER have the competence to offer innovative solutions in bevel gear technology and gearbox assembly suiting a wide range of industrial gearing applications. MS-GRAESSNER are the ideal partner for you.



Content

	<i>Page</i>
<i>Highlights</i>	4–5
<i>Performance tables</i>	6–8
<i>Symbols and units</i>	9
<i>Dimensions and shaft arrangements</i>	10–17
<i>Selection</i>	18
<i>Mounting positions</i>	19
<i>Accessories / Options</i>	20–21
<i>Lubrication</i>	22
<i>Technical service and maintenance</i>	23
<i>Ordering codes</i>	24

Internal highlights

The design of the new PowerGear range has been influenced by extremely varied applications within many industry sectors.

The PowerGear range has been developed with a specific torque/speed relationship in mind and therefore benefits from many advantages.

- The compact and rigid design ensures highest performance whilst being space and weight efficient.
- Lubricated for life, the gearboxes up to and including size P/X 140 are virtually maintenance-free under normal operating conditions.
- The high efficiency rating of 98% saves energy costs.

Optimized Gleason gearing for high torque rating

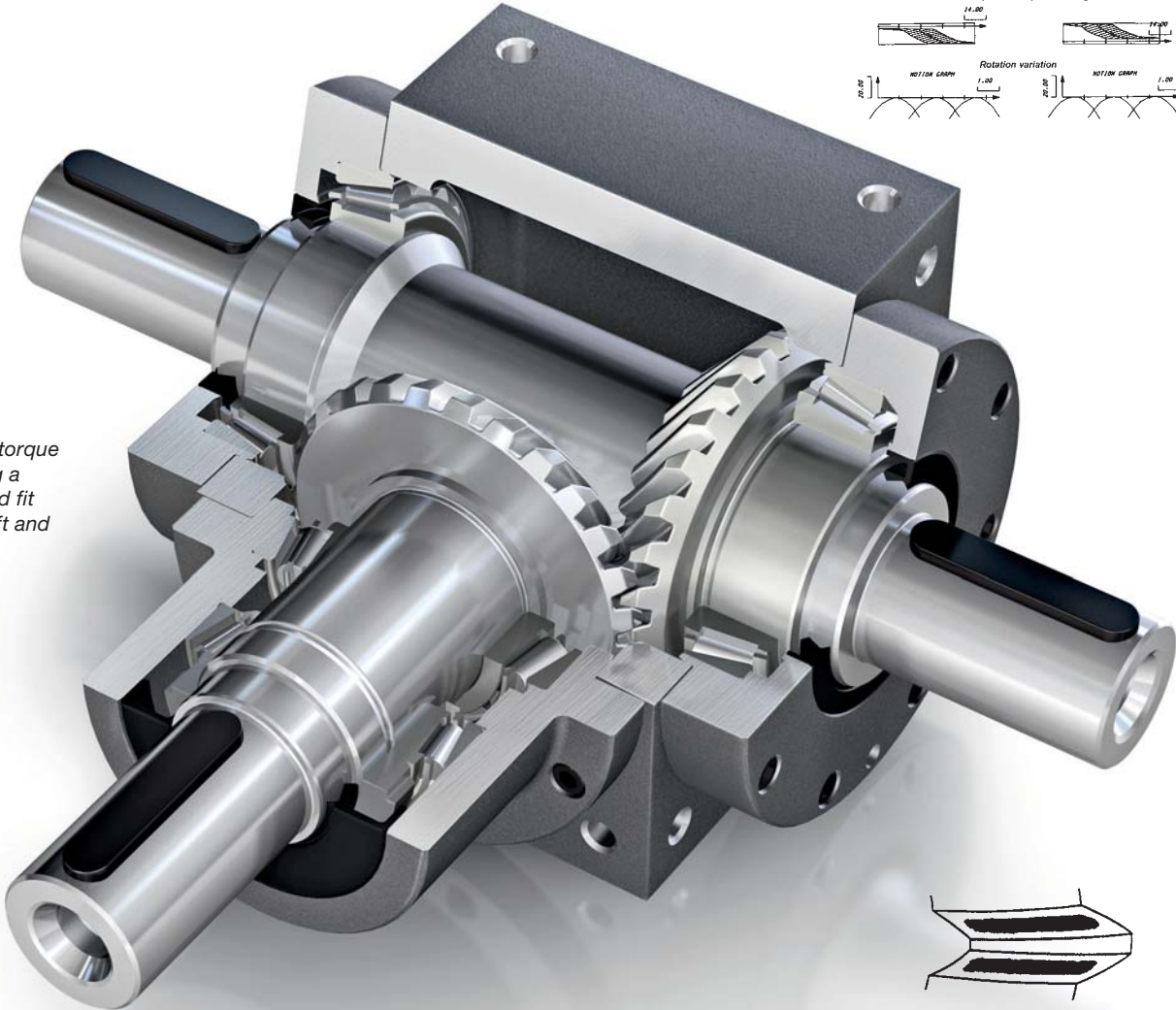
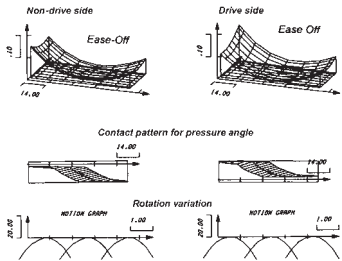

Fretting-free torque transfer using a friction-locked fit between shaft and bevel gear

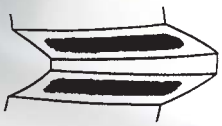

Optimized contact pattern assembly for uniform load distribution

External highlights

POWER GEAR

Simply choose the PowerGear to suit your application.

- 11 gearbox sizes, from P54 to P450
- 9 additional gearbox sizes in reinforced design, ratio $i = 1:1$, from X54 to X280
- Ratios from $i = 1:1$ to 5:1
- Input speeds
Up to 7500 min^{-1} for P-Version, dependent on size
Up to 4000 min^{-1} for X-Version, dependent on size
- Flange, solid or hollow shaft version

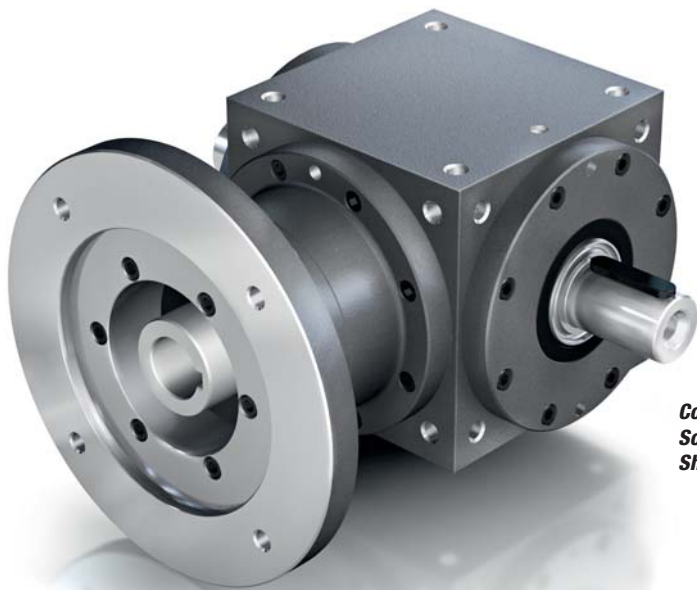

Configuration FL
Solid shaft version with input flange
Shaft arrangement 13

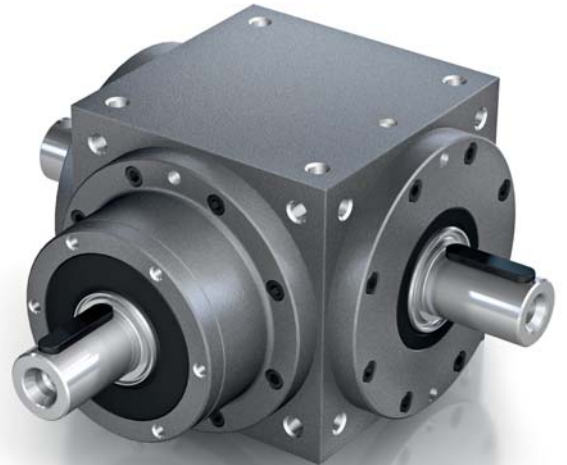

Configuration L
Solid shaft version
Shaft arrangement 13



Configuration FH
Hollow shaft version with input flange
Shaft arrangement 13



Configuration H
Hollow shaft version
Shaft arrangement 13

		Abbr	Unit	P54	P75	P90	P110	P140	P170	P210	P240	P280
Output torque	i=1:1	T _{2N}	Nm	15	45	78	150	360	585	1300	2150	3200
		T _{2B}	Nm	23	68	117	225	540	878	1950	3225	4800
		T _{2Not}	Nm	30	90	156	300	720	1170	2600	4300	6400
	i=1,5:1	T _{2N}	Nm	15	45	78	150	360	585	1300	2150	3200
		T _{2B}	Nm	23	68	117	225	540	878	1950	3225	4800
		T _{2Not}	Nm	30	90	156	300	720	1170	2600	4300	6400
	i=2:1	T _{2N}	Nm	12	42	68	150	330	544	1220	2010	3050
		T _{2B}	Nm	18	63	102	225	495	816	1830	3015	4575
		T _{2Not}	Nm	24	84	136	300	660	1088	2440	4020	6100
	i=3:1	T _{2N}	Nm	12	33	54	120	270	450	1020	1650	2850
		T _{2B}	Nm	18	50	81	180	405	675	1530	2475	4275
		T _{2Not}	Nm	24	66	108	240	540	900	2040	3300	5700
i=4:1	T _{2N}	Nm	–	28	52	100	224	376	860	1410	2300	
	T _{2B}	Nm	–	42	78	150	336	564	1290	2115	3450	
	T _{2Not}	Nm	–	56	104	200	448	752	1720	2820	4600	
i=5:1	T _{2N}	Nm	–	25	40	85	196	320	740	1210	2000	
	T _{2B}	Nm	–	38	60	128	294	480	1110	1815	3000	
	T _{2Not}	Nm	–	50	80	170	392	640	1480	2420	4000	
Input speed	i= 1:1	n _{1nenn}	min ⁻¹	2500	2000	1700	1400	1100	1000	800	700	650
	i= 1,5:1 ; 2:1	n _{1nenn}	min ⁻¹	3000	2500	2000	1600	1400	1300	1050	950	850
	i= 3:1 ; 4:1 ; 5:1	n _{1nenn}	min ⁻¹	3500	3000	2500	2100	2000	1800	1600	1350	1200
Applies at 20% of nominal torque at 20° C ambient temperature		n _{1max} **	min ⁻¹	7500	6500	5500	4500	3500	3000	2200	2000	1700
	**On request, special measures required											
Output backlash	Standard		arcmin	≤ 18	≤ 15	≤ 14	≤ 13	≤ 12	≤ 12	≤ 11	≤ 11	≤ 11
	Assuming 2% load and max. 10 Nm at the output	reduced	arcmin	≤ 12	≤ 9	≤ 8	≤ 8	≤ 7	≤ 6	≤ 6	≤ 6	≤ 6
Permissible radial load		F _{1Rmax} *	N	300	900	1300	2000	3500	5000	8500	11000	15000
		F _{2Rmax} *	N	400	1100	1600	2500	4500	6000	10500	15000	18000
Permissible axial load		F _{1Amax}	N	150	450	650	1000	1750	2500	4250	5500	7500
		F _{2Amax}	N	200	550	800	1250	2250	3000	5250	7500	9000
Efficiency at max load		n	%	> 98	> 98	> 98	> 98	> 98	> 98	> 98	> 98	> 98
Running noise at 1500 min ⁻¹		LpA	db(A)	≤ 70	≤ 70	≤ 74	≤ 76	≤ 77	≤ 78	≤ 80	≤ 82	≤ 83
Weight approx.		m	kg	1,8	4,5	8,0	13,0	22,0	38,5	71,0	103,5	155,0
Service life		Lh	h	> 15000	> 15000	> 15000	> 15000	> 15000	> 15000	> 15000	> 15000	> 15000
Lubrication	Synthetic oil, ISO VG 150, up to size P140 inclusive											
Average oil quantity			litre	0,05	0,10	0,20	0,30	0,40	1,00	2,20	2,60	3,00
Operating temperature			°C	up to 80								
Paint	Primary coated RAL 9005 – dull black											
Mass moments of inertia related to input for shaft arrangement WA 13	i=1,0:1	I ₁	kgcm ²	0,28	1,79	4,93	12,5	36,8	85,9	287	592	1190
	i=1,5:1	I ₁	kgcm ²	0,15	1,22	3,45	9,17	22,4	54,6	179	373	762
	i=2,0:1	I ₁	kgcm ²	0,11	0,95	2,78	7,41	15,6	39,3	123	253	506
	i=3,0:1	I ₁	kgcm ²	0,09	0,78	2,34	6,18	10,9	28,5	84,1	167	328
	i=4,0:1	I ₁	kgcm ²	–	0,72	2,18	5,71	9,19	24,5	69,9	136	263
	i=5,0:1	I ₁	kgcm ²	–	0,69	2,10	5,48	8,32	22,6	62,7	120	230

* Centre of shaft

Thermal performance limit

	P54	P75	P90	P110	P140	P170	P210	P240	P280
Thermal performance limit P _{therm} (KW) at 20 °C and duty cycle of 100%	1,6	2,9	4,1	5,7	9,2	13,2	21,2	28,4	38,4

The gearbox performance is limited by the maximum permissible oil bath temperature. The actual effective performance must not exceed the permissible limit when in continuous operation.

For intermittent operation or in the event of increased ambient temperatures, the following factors can be applied as guide values for determining the permissible thermal performance limit.

Duty cycle (dc) in %	100	80	60	40	20
Factor	1,00	1,20	1,40	1,60	1,80

Ambient temperature °C	10	20	30	40	50
Factor	1,20	1,00	0,87	0,75	0,62

Example	Gearbox	dc	Ambient Temperature
P _{therm}	P140	80 %	30 °C
Thermal performance limit			
P _{therm} =	9,2	x	1,20
	x	0,87	=
	9,6	KW	

Applicable is: P_{exist.} ≤ P_{therm}

As a function of the thermal power limit, higher speeds at a reduced torque are possible. For an optimal design of your application, please contact us.

Please see gearbox selection and installation on page 18+19!

		Abbr.	Unit	P360	P450	
Output torque	i=1:1	T _{2N}	Nm	3750	6600	
		T _{2B}	Nm	5625	9900	
		T _{2Not}	Nm	7500	13200	
	i=1,5:1	T _{2N}	Nm	3550	7000	
		T _{2B}	Nm	5325	10500	
		T _{2Not}	Nm	7100	14000	
	i=2:1	T _{2N}	Nm	3500	7000	
		T _{2B}	Nm	5250	10500	
		T _{2Not}	Nm	7000	14000	
	i=3:1	T _{2N}	Nm	3350	7000	
		T _{2B}	Nm	5025	10500	
		T _{2Not}	Nm	6700	14000	
	i=4:1	T _{2N}	Nm	2900	6600	
		T _{2B}	Nm	4350	9900	
		T _{2Not}	Nm	5800	13200	
i=5:1	T _{2N}	Nm	2600	6000		
	T _{2B}	Nm	3900	9000		
	T _{2Not}	Nm	5200	12000		
Input speed	i= 1:1	n _{1nenn}	min ⁻¹	650	550	
	i= 1,5:1 ; 2:1	n _{1nenn}	min ⁻¹	850	800	
	Applies at 20% of nominal torque at 20° C ambient temperature	i= 3:1 ; 4:1 ; 5:1	n _{1nenn}	min ⁻¹	1200	1100
			n _{1max} **	min ⁻¹	1400	1300
			**On request, special measures required			
Output backlash	Standard		arcmin	≤ 11	≤ 10	
	Assuming 2% load and max. 10 Nm at the output reduced		arcmin	≤ 6	≤ 5	
Permissible radial load	i=1:1 – 2:1	F _{1Rmax} *	N	18000	22000	
		F _{1Rmax} *	N	15000	18000	
	i=4:1	F _{1Rmax} *	N	11000	15000	
	i=5:1	F _{1Rmax} *	N	9000	11000	
	i=1:1 – 5:1	F _{2Rmax} *	N	24000	34000	
Permissible axial load	i=1:1 – 2:1	F _{1Amax}	N	9000	11000	
		F _{1Amax}	N	7500	9000	
	i=4:1	F _{1Amax}	N	5500	7500	
	i=5:1	F _{1Amax}	N	4500	5500	
	i=1:1 – 5:1	F _{2Amax}	N	12000	17000	
Efficiency at max load		n	%	> 98	> 98	
Running noise at 1500 min ⁻¹		LpA	db(A)	≤ 85	≤ 85	
Weight approx.		m	kg	240,0	400,0	
Service life		Lh	h	> 15000	> 15000	
Lubrication	Delivery by default without oil					
Average oil quantity			litre	9,00	22,00	
Operating temperature			°C	up to 80	up to 80	
Paint	Primary coated RAL 9005 - dull black					
Mass moments of inertia related to input for shaft arrangement WA 13	i=1,0:1	I1	kgcm ²	2314	7632	
	i=1,5:1	I1	kgcm ²	1270	4152	
				877	2764	
	i=3,0:1	I1	kgcm ²	467	1596	
	i=4,0:1	I1	kgcm ²	316	1077	
	i=5,0:1	I1	kgcm ²	219	750	

* Centre of shaft

Thermal performance limit

	P360	P450
Thermal performance limit P _{therm} (KW) at 20 °C and duty cycle of 100 %	60	93,4

The gearbox performance is limited by the maximum permissible oil bath temperature. The actual effective performance must not exceed the permissible limit when in continuous operation.

Duty cycle (dc) in %	100	80	60	40	20
Factor	1,00	1,20	1,40	1,60	1,80

For intermittent operation or in the event of increased ambient temperatures, the following factors can be applied as guide values for determining the permissible thermal performance limit.

Ambient temperature °C	10	20	30	40	50
Factor	1,20	1,00	0,87	0,75	0,62

As a function of the thermal power limit, higher speeds at a reduced torque are possible. For an optimal design of your application, please contact us.

Example	Gearbox	dc	Ambient Temperature
P _{therm}	P140	80 %	30 °C
Thermal performance limit P _{therm} =	9,2	x 1,20	x 0,87 = 9,6 KW

Please see gearbox selection and installation on page 18+19!

Applicable is: P_{exist.} ≤ P_{therm}

Performance table

X-Version reinforced design

POWER GEAR

	Abbr	Unit	X54	X75	X90	X110	X140	X170	X210	X240	X280	
Output torque	$i=1:1$	T_{2N}	Nm	24	87	135	290	625	1020	2050	3350	5200
		T_{2B}	Nm	36	131	203	435	938	1530	3075	5025	7800
		T_{2Not}	Nm	48	174	270	580	1250	2040	4100	6700	10400
Input speed	n_{1nenn}	min^{-1}	2200	1800	1500	1100	900	850	700	600	500	
Applies at 20% of nominal torque at 20° C ambient temperature	n_{1max} **	min^{-1}	4000	3000	2500	2000	2000	1500	1200	1200	1000	
	**On request, special measures required											
Output backlash	Standard	arcmin	≤ 18	≤ 15	≤ 14	≤ 13	≤ 12	≤ 12	≤ 11	≤ 11	≤ 11	
Assuming 2% load and max. 10 Nm at the output	Reduced	arcmin	≤ 12	≤ 9	≤ 8	≤ 8	≤ 7	≤ 6	≤ 6	≤ 6	≤ 6	
Permissible radial load	F_{1Rmax} *	N	400	1500	2000	3500	5500	7800	12000	16000	20000	
	F_{2Rmax} *	N	600	2000	2700	4500	7500	11000	16000	21000	30000	
Permissible axial load	F_{1Amax}	N	200	750	1000	1750	2750	3900	6000	8000	10000	
	F_{2Amax}	N	300	1000	1350	2250	3750	5500	8000	10500	15000	
Efficiency at max load	η	%	> 98	> 98	> 98	> 98	> 98	> 98	> 98	> 98	> 98	
Running noise at 1500 min^{-1}	LpA	db(A)	≤ 70	≤ 70	≤ 74	≤ 76	≤ 77	≤ 78	≤ 80	≤ 82	≤ 83	
Weight approx.	m	kg	1,9	5,0	8,5	13,5	22,5	39,0	71,5	104,0	155,5	
Service life	Lh	h	> 15000	> 15000	> 15000	> 15000	> 15000	> 15000	> 15000	> 15000	> 15000	
Lubrication	Synthetic oil, ISO VG 150, up to size X140 inclusive											
Average oil quantity		litre	0,1	0,1	0,2	0,3	0,4	1,0	2,2	2,6	3,0	
Operating temperature		°C	up to 80									
Paint	Primary coated RAL 9005 – dull black											
Mass moments of inertia related to input for shaft arrangement WA 13		kgcm ²	0,34	2,26	5,99	21,4	61,3	142	485	987	2150	

* Centre of shaft

Thermal performance limit

	X54	X75	X90	X110	X140	X170	X210	X240	X280
Thermal performance limit P_{therm} (KW) at 20 °C and duty cycle of 100 %	1,6	2,9	4,1	5,7	9,2	13,2	21,2	28,4	38,4

The gearbox performance is limited by the maximum permissible oil bath temperature. The actual effective performance must not exceed the permissible limit when in continuous operation.

For intermittent operation or in the event of increased ambient temperatures, the following factors can be applied as guide values for determining the permissible thermal performance limit.

Duty cycle (dc) in %	100	80	60	40	20
Factor	1,00	1,20	1,40	1,60	1,80

Ambient temperature °C	10	20	30	40	50
Factor	1,20	1,00	0,87	0,75	0,62

As a function of the thermal power limit, higher speeds at a reduced torque are possible. For an optimal design of your application, please contact us.

Please see gearbox selection and installation on page 18+19!

Example:	Gearbox	dc	Ambient Temperature
P_{therm}	X140	80 %	30 °C
Thermal performance limit $P_{therm} =$	9,2	x 1,20	x 0,87 = 9,6 KW

Applicable is: $P_{exist.} \leq P_{therm}$

Maximum motor acceleration torque	T_{1BMot}	Nm
Nominal output torque	T_{2N}	Nm
Maximum output acceleration	T_{2B}	Nm
EMERGENCY STOP output torque	T_{2Not}	Nm
Maximum input speed	n_{1max}	min^{-1}
Nominal input speed	n_{1N}	min^{-1}
Output backlash	j_t	arcmin
Torsional output stiffness	C_{t21}	Nm/arcmin
Radial input force	F_{1Rmax}	N
Radial output force	F_{2Rmax}	N
Axial input force	F_{1Amax}	N
Axial output force	F_{2Amax}	N
Efficiency at full load	η	%
Running noise	L_{pA}	dB(A)
Weight	m	kg
Mass moment of inertia	I_1	kgcm^2
Service life	L_h	h
Run time	RT	min
Duty cycle	DC	%
Ambient temperature	t_a	$^{\circ}\text{C}$
Thermal performance limit	P_{therm}	kW
Performance	P	kW

Dimensions and shaft arrangements

P-Version configuration L

POWER GEAR

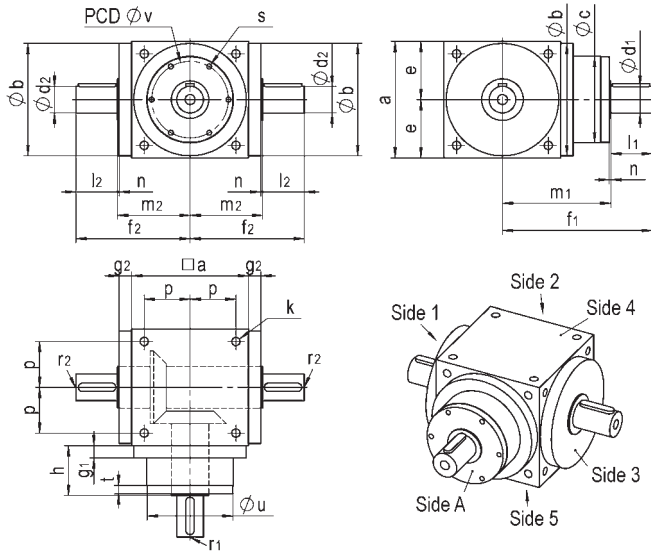

Always right view = mirrored illustration

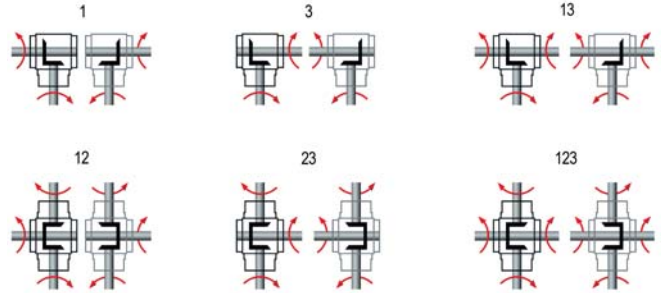

	P54L	P75L	P90L	P110L	P140L	P170L	P210L	P240L	P280L
a	54	75	90	110	140	170	210	240	280
Øb_{h7}	53	73	88	108	135	165	205	235	275
Øc	53	72	86	106	104	128	160	180	200
Ød_{1 k6}	11	16	18	22	32	40	50	55	60
l₁	23	30	35	40	50	60	75	85	110
Ød_{2 k6}	11	16	18	22	32	40	50	55	60
l₂	23	30	35	40	50	60	75	85	110
e	27	37,5	45	55	70	85	105	120	140
f₁	95	120	135	155	180	215	265	300	360
f₂	60	84	97	112	137	162	202	231	276
g₁	43	15	15	15	15	15	20	25	25
g₂	9	14,5	15	15	15	15	20	25	25
h	45	52,5	55	60	60	70	85	95	110
k	M5 x14,5*	M6 x12	M6 x12	M8 x15,5	M10 x19,5	M12 x23	M16 x30	M16 x30	M16 x30
m₁	72	90	100	115	130	155	190	215	250
m₂	37	54	62	72	87	102	127	147	167
n₁	2	2	2	2	2	2	2	2	2
n₂	1	2	2	2	2	2	2	2	2
p	22	30	36	44	55	67	85	95	110
r_{1**}	M4	M5	M6	M8	M12	M16	M16	M20	M20
r_{2**}	M4	M5	M6	M8	M12	M16	M16	M20	M20
s	–	4x M5 x9	4x M5 x12	6x M6 x12	6x M6 x12	6x M8 x14	6x M8 x14	6x M8 x14	6x M10 x17
t	–	8	8	8	10	10	10	10	10
Øu_{g6}	–	72,9	87	107	103	127	158	178	198
Øv	–	62	76	92	92	114	142	160	176
Key_{d1}	4x4x18	5x5x25	6x6x28	6x6x32	10x8x45	12x8x50	14x9x70	16x10x80	18x11x100
Key_{d2}	4x4x18	5x5x25	6x6x28	6x6x32	10x8x45	12x8x50	14x9x70	16x10x80	18x11x100

* Thread starts from 7.00 mm depth

** According to Form D, DIN332

Dimensions and shaft arrangements

P-Version configuration H

POWER GEAR

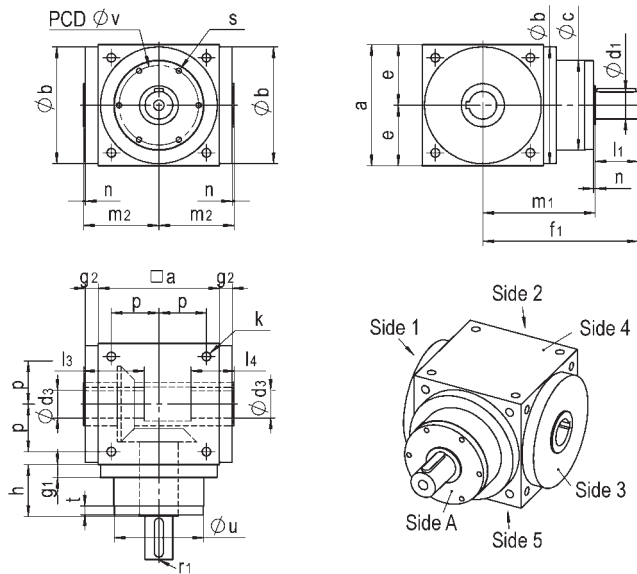

Always right view = mirrored illustration

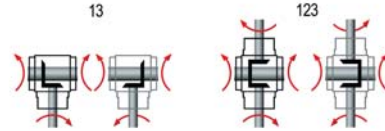

	P75H	P90H	P110H	P140H	P170H	P210H	P240H	P280H
a	75	90	110	140	170	210	240	280
Øb _{h7}	73	88	108	135	165	205	235	275
Øc	72	86	106	104	128	160	180	200
Ød _{1 k6}	16	18	22	32	40	50	55	60
l ₁	30	35	40	50	60	75	85	110
Ød _{3 h7}	14	18	22	32	40	50	55	60
l ₃	47	55	60	70	80	95	115	130
l ₄	32	35	40	50	55	65	80	80
e	37,5	45	55	70	85	105	120	140
f ₁	120	135	155	180	215	265	300	360
g ₁	15	15	15	15	15	20	25	25
g ₂	14,5	15	15	15	15	20	25	25
h	52,5	55	60	60	70	85	95	110
k	M6 x12	M6 x12	M8 x15,5	M10 x19,5	M12 x23	M16 x30	M16 x30	M16 x30
m ₁	90	100	115	130	155	190	215	250
m ₂	54	62	72	87	102	127	147	167
n ₁	2	2	2	2	2	2	2	2
n ₂	2	2	2	2	2	2	2	2
p	30	36	44	55	67	85	95	110
r ₁ **	M5	M6	M8	M12	M16	M16	M20	M20
s	4x M5 x9	4x M5 x12	6x M6 x12	6x M6 x12	6x M8 x14	6x M8 x14	6x M8 x14	6x M10 x17
t	8	8	8	10	10	10	10	10
Øu _{g6}	72,9	87	107	103	127	158	178	198
Øv	62	76	92	92	114	142	160	176
Key _{d1}	5x5x25	6x6x28	6x6x32	10x8x45	12x8x50	14x9x70	16x10x80	18x11x100
Key _{d2}	5x5	6x6	6x6	10x8	12x8	14x9	16x10	18x11

** According to Form D, DIN332

Dimensions and shaft arrangements

P-Version configuration L

POWER GEAR

Always right view = mirrored illustration

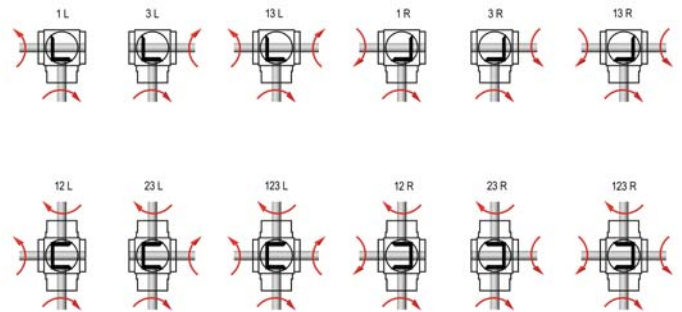
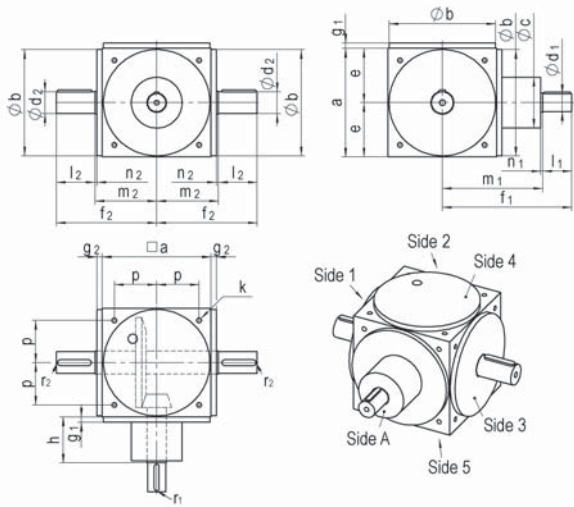

		P360L	P450L
a	i=1:1 – 5:1	360	450
Øb h7	i=1:1 – 5:1	350	440
Øc	i=1:1 – 2:1	210	250
	i=3:1 – 5:1	170	210
Ød1 k6	i=1:1 – 2:1	75	90
	i=3:1	60	75
	i=4:1	55	70
	i=5:1	50	60
l1	i=1:1 – 2:1	120	160
	i=3:1	110	120
	i=4:1	85	120
	i=5:1	80	110
Ød2 k6	i=1:1 – 5:1	75	90
l2	i=1:1 – 5:1	120	160
e	i=1:1 – 5:1	180	225
f1	i=1:1 – 2:1	445	570
	i=3:1	435	530
	i=4:1	410	530
	i=5:1	405	520
f2	i=1:1 – 5:1	325	410
g1	i=1:1 – 5:1	22	22
g2	i=1:1 – 5:1	22	22
h	i=1:1 – 5:1	145	185
k	i=1:1 – 5:1	M20 x37,5	M20 x37,5
m1	i=1:1 – 5:1	325	410
m2	i=1:1 – 5:1	205	250
n1	i=1:1 – 5:1	3	3
n2	i=1:1 – 5:1	3	3
p	i=1:1 – 5:1	140	175
r1**	i=1:1 – 2:1	M20	M24
	i=3:1	M20	M20
	i=4:1	M20	M20
	i=5:1	M16	M20
r2**	i=1:1 – 5:1	M20	M24
s	i=1:1 – 5:1	–	–
t	i=1:1 – 5:1	–	–
Øu g6	i=1:1 – 5:1	–	–
Øv	i=1:1 – 5:1	–	–
Key_{d1}	i=1:1 – 2:1	20x12x110	25x14x140
	i=3:1	18x11x100	20x12x110
	i=4:1	16x10x80	20x12x110
	i=5:1	14x9x70	18x11x100
Key_{d2}	i=1:1 – 5:1	20x12x110	25x14x140

** According to Form D, DIN332

Dimensions and shaft arrangements

P-Version configuration H

POWER GEAR

Always right view = mirrored illustration

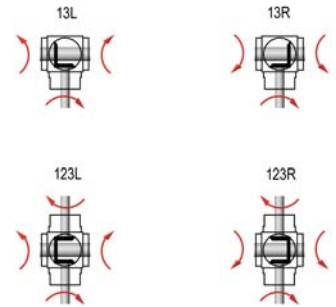
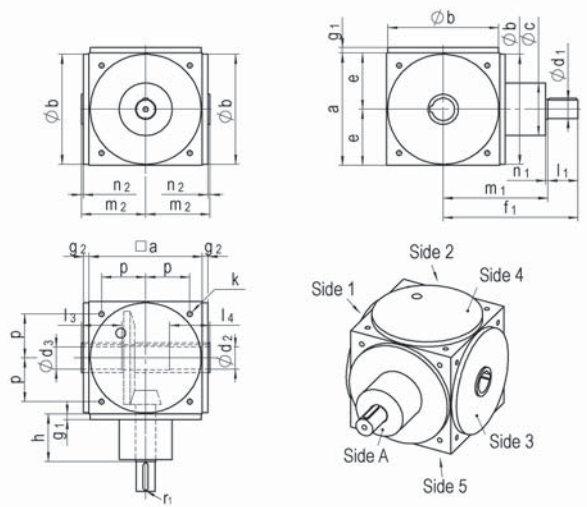

		P360H	P450H
a	i=1:1 – 5:1	360	450
Øb h7	i=1:1 – 5:1	350	440
Øc	i=1:1 – 2:1	210	250
	i=3:1 – 5:1	170	210
Ød1 k6	i=1:1 – 2:1	75	90
	i=3:1	60	75
	i=4:1	55	70
	i=5:1	50	60
l1	i=1:1 – 2:1	120	160
	i=3:1	110	120
	i=4:1	85	120
	i=5:1	80	110
Ød3 h7	i=1:1 – 5:1	75	90
l3	i=1:1 – 5:1	165	200
l4	i=1:1 – 5:1	105	140
e	i=1:1 – 5:1	180	225
f1	i=1:1 – 2:1	445	570
	i=3:1	435	530
	i=4:1	410	530
	i=5:1	405	520
g1	i=1:1 – 5:1	22	22
g2	i=1:1 – 5:1	22	22
h	i=1:1 – 5:1	145	185
k	i=1:1 – 5:1	M20 x37,5	M20 x37,5
m1	i=1:1 – 5:1	325	410
m2	i=1:1 – 5:1	205	250
n1	i=1:1 – 5:1	3	3
n2	i=1:1 – 5:1	3	3
p	i=1:1 – 5:1	140	175
r1**	i=1:1 – 2:1	M20	M24
	i=3:1	M20	M20
	i=4:1	M20	M20
	i=5:1	M16	M20
s	i=1:1 – 5:1	–	–
t	i=1:1 – 5:1	–	–
Øu g6	i=1:1 – 5:1	–	–
Øv	i=1:1 – 5:1	–	–
Key d1	i=1:1 – 2:1	20x12x110	25x14x140
	i=3:1	18x11x100	20x12x110
	i=4:1	16x10x80	20x12x110
	i=5:1	14x9x70	18x11x100
Key d2	i=1:1 – 5:1	20x12	25x14

** According to Form D, DIN332

www.graessner.de

Dimensions and shaft arrangements

P-Version configuration FL

POWER GEAR

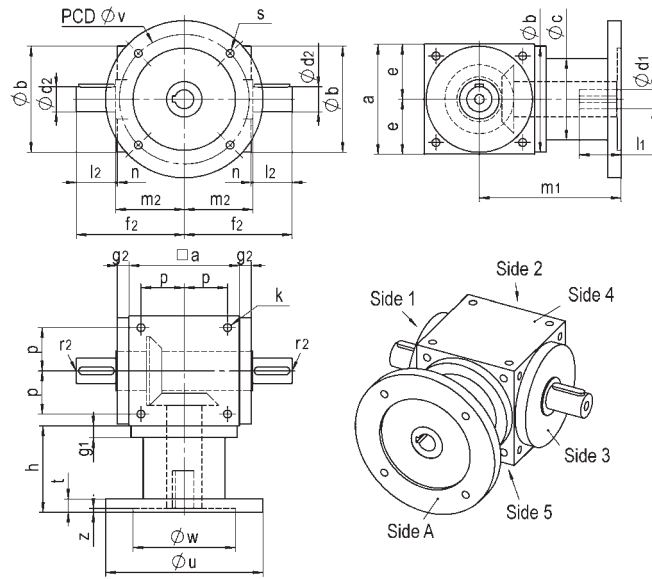

Always right view = mirrored illustration

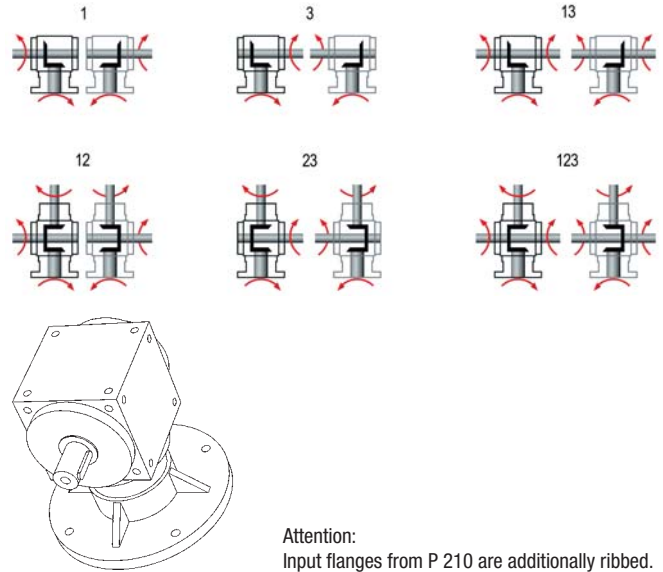

Attention:
Input flanges from P 210 are additionally ribbed.

	P75FL	P90FL	P110FL	P140FL	P170FL	P210FL	P240FL	P280FL
a	75	90	110	140	170	210	240	280
Øb _{h7}	73	88	108	135	165	205	235	275
Øc	72	86	106	104	128	160	180	200
Ød _{2 k6}	16	18	22	32	40	50	55	60
l ₂	30	35	40	50	60	75	85	110
e	37,5	45	55	70	85	105	120	140
f ₂	84	97	112	137	162	202	231	276
g ₁	15	15	15	15	15	20	25	25
g ₂	14,5	15	15	15	15	20	25	25
h	62,5	68	80	110	130	170	180	185
k	M6 x12	M6 x12	M8 x15,5	M10 x19,5	M12 x23	M16 x30	M16 x30	M16 x30
m ₁	102	113	135	180	215	275	300	325
m ₂	54	62	72	87	102	127	147	167
n ₂	2	2	2	2	2	2	2	2
p	30	36	44	55	67	85	95	110
r ₂ **	M5	M6	M8	M12	M16	M16	M20	M20
t	14	14	17	17	20	20	20	20
Key _{d2}	5x5x25	6x6x28	6x6x32	10x8x45	12x8x50	14x9x70	16x10x80	18x11x100
Z	4,5	4,5	5	5	6	6	6	6

Also available with flange and coupling

Input shaft Ød₁^{G7} x L1 with keyway bxh to DIN 6885/1

14x33/5x5	14x33/5x5	19x43/6x6	24x53/8x7	28x63/8x7	38x83/10x8	38x83/10x8	48x115/14x9
	19x43/6x6	24x53/8x7	28x63/8x7	32x83/10x8	42x115/12x8	42x115/12x8	55x115/16x10
			32x63/10x8	38x83/10x8	48x115/14x9	48x115/14x9	

Input flange B5 Øu / Øv with 4 threaded holes s / Øw^{F7}

120/100+6/80	120/100+6/80	120/100+6/80	160/130+8/110	200/165+10/130		250/215+12/180	300/265+12/230
140/115+8/95	140/115+8/95	140/115+8/95	200/165+10/130	250/215+12/180	250/215+12/180	300/265+12/230	350/300+16/250
160/130+8/110	160/130+8/110	160/130+8/110	250/215+12/180	300/265+12/230	300/265+12/230	350/300+16/250	400/350+16/300
200/165+10/130	200/165+10/130	200/165+10/130	300/265+12/230	350/300+16/250	350/300+16/250	400/350+16/300	450/400+16/350

Input flange B14 Øu / Øv with bore holes s / Øw^{F7}

120/100+6,6/80							
140/115+9/95	140/115+9/95						
160/130+9/110	160/130+9/110	160/130+9/110	160/130+9/110				
200/165+11/130	200/165+11/130	200/165+11/130	200/165+11/130	200/165+11/130			

** According to Form D, DIN332

Dimensions and shaft arrangements

P-Version configuration FH

POWER GEAR

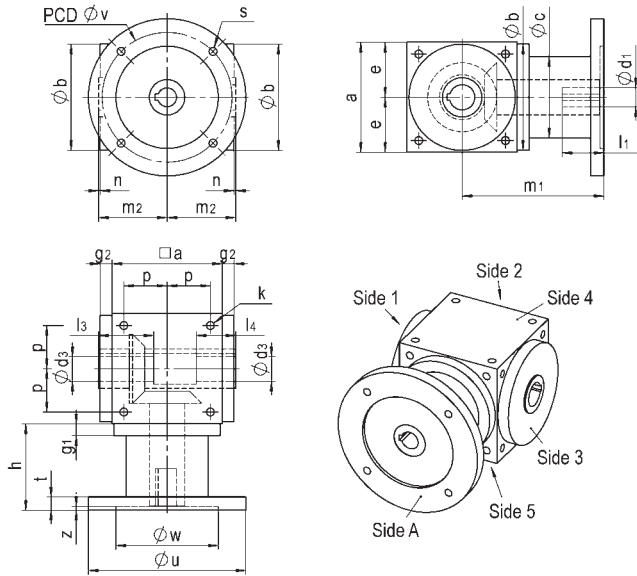

Always right view = mirrored illustration

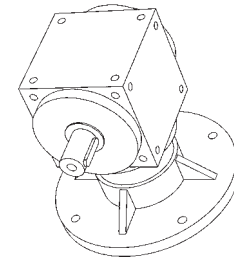
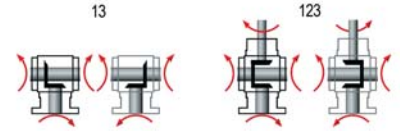

Attention:
Input flanges from P 210 are additionally ribbed.

	P75FH	P90FH	P110FH	P140FH	P170FH	P210FH	P240FH	P280FH
a	75	90	110	140	170	210	240	280
Øb _{h7}	73	88	108	135	165	205	235	275
Øc	72	86	106	104	128	160	180	200
Ød _{3 h7}	14	18	22	32	40	50	55	60
e	37,5	45	55	70	85	105	120	140
g ₁	15	15	15	15	15	20	25	25
g ₂	14,5	15	15	15	15	20	25	25
h	62,5	68	80	110	130	170	180	185
k	M6 x12	M6 x12	M8 x15,5	M10 x19,5	M12 x23	M16 x30	M16 x30	M16 x30
l ₃	47	55	60	70	80	95	115	130
l ₄	32	35	40	50	55	65	80	80
m ₁	102	113	135	180	215	275	300	325
m ₂	54	62	72	87	102	127	147	167
n ₂	2	2	2	2	2	2	2	2
p	30	36	44	55	67	85	95	110
t	14	14	17	17	20	20	20	20
Key _{d3}	5x5	6x6	6x6	10x8	12x8	14x9	16x10	18x11
Z	4,5	4,5	5	5	6	6	6	6

Also available with flange and coupling

Input shaft Ød₁^{G7} x L1 with keyway bxh to DIN 6885/1

14x33/5x5	14x33/5x5	19x43/6x6	24x53/8x7	28x63/8x7	38x83/10x8	38x83/10x8	48x115/14x9
	19x43/6x6	24x53/8x7	28x63/8x7	32x83/10x8	42x115/12x8	42x115/12x8	55x115/16x10
			32x63/10x8	38x83/10x8	48x115/14x9	48x115/14x9	

Input flange B5 Øu / Øv with 4 threaded holes s / Øw^{F7}

120/100+6/80	120/100+6/80	120/100+6/80	160/130+8/110	200/165+10/130		250/215+12/180	300/265+12/230
140/115+8/95	140/115+8/95	140/115+8/95	200/165+10/130	250/215+12/180	250/215+12/180	300/265+12/230	350/300+16/250
160/130+8/110	160/130+8/110	160/130+8/110	250/215+12/180	300/265+12/230	300/265+12/230	350/300+16/250	400/350+16/300
200/165+10/130	200/165+10/130	200/165+10/130	300/265+12/230	350/300+16/250	350/300+16/250	400/350+16/300	450/400+16/350

Input flange B14 Øu / Øv with bore holes s / Øw^{F7}

120/100+6,6/80							
140/115+9/95	140/115+9/95						
160/130+9/110	160/130+9/110	160/130+9/110	160/130+9/110				
200/165+11/130	200/165+11/130	200/165+11/130	200/165+11/130	200/165+11/130			

www.graessner.de

Dimensions and shaft arrangements

X-Version reinforced design configuration L

POWER GEAR

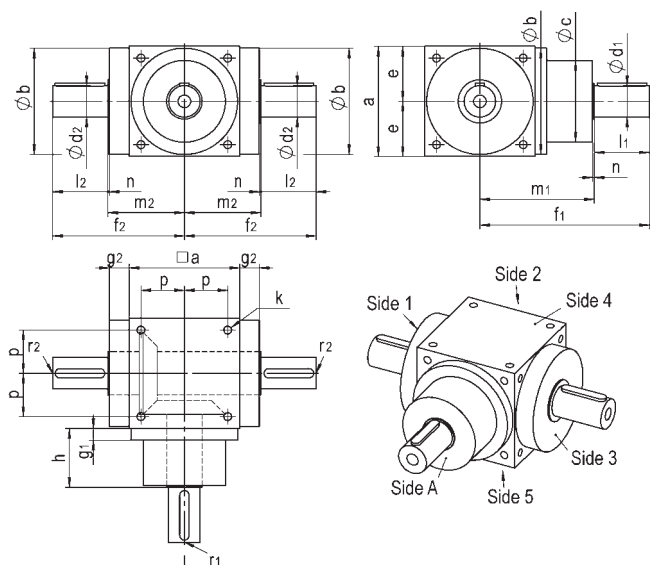

Always right view = mirrored illustration

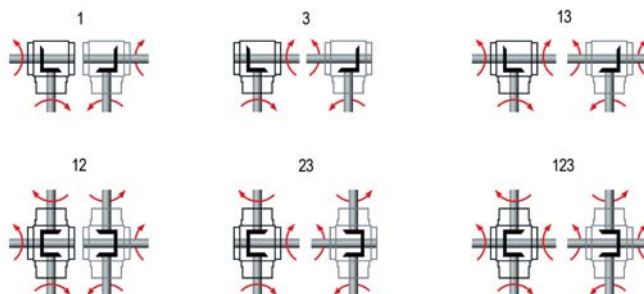

	X54L	X75L	X90L	X110L	X140L	X170L	X210L	X240L	X280L
a	54	75	90	110	140	170	210	240	280
Øb_{h7}	53	73	88	108	135	165	205	235	275
Øc	53	72	86	106	104	128	160	180	200
Ød_{1 k6}	14	20	25	35	40	50	60	70	80
l₁	30	35	40	60	70	80	110	120	150
Ød_{2 k6}	14	20	25	35	40	50	60	70	80
l₂	30	35	40	60	70	80	110	120	150
e	27	37,5	45	55	70	85	105	120	140
f₁	102	125	140	175	215	255	320	360	425
f₂	69	93	105	140	167	197	252	282	338
g₁	43	15	15	15	15	15	20	25	25
g₂	11	18,5	18	23	25	30	35	40	46
h	45	52,5	55	60	75	90	105	120	135
k	M5 x14,5*	M6 x12	M6 x12	M8 x15,5	M10 x19,5	M12 x23	M16 x30	M16 x30	M16 x30
m₁	72	90	100	115	145	175	210	240	275
m₂	39	58	65	80	97	117	142	162	188
n₁	2	2	2	2	2	2	2	2	2
n₂	1	2	2	2	2	2	2	2	2
p	22	30	36	44	55	67	85	95	110
r_{1**}	M5	M6	M10	M12	M16	M16	M20	M20	M20
r_{2**}	M5	M6	M10	M12	M16	M16	M20	M20	M20
s	–	4x M5 x9	4x M5 x12	6x M6 x12	–	–	–	–	–
t	–	8	8	8	–	–	–	–	–
Øu_{g6}	–	72,9	87	107	–	–	–	–	–
Øv	–	62	76	92	–	–	–	–	–
Key_{d1}	5x5x25	6x6x28	8x7x32	10x8x50	12x8x63	14x9x70	18x11x100	20x12x110	22x14x140
Key_{d2}	5x5x25	6x6x28	8x7x32	10x8x50	12x8x63	14x9x70	18x11x100	20x12x110	22x14x140

* Thread starts from 7.00 mm depth

** According to Form D, DIN332

Dimensions and shaft arrangements

X-Version reinforced design

configuration H

POWER GEAR

Always right view = mirrored illustration

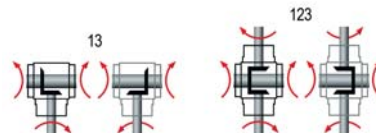
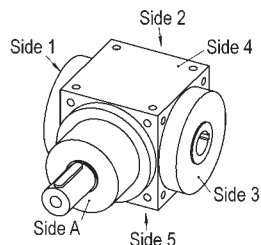
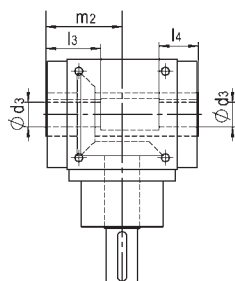

	X75H	X90H	X110H	X140H	X170H	X210H	X240H	X280H
a	75	90	110	140	170	210	240	280
Øb_{h7}	73	88	108	135	165	205	235	275
Øc	72	86	106	104	128	160	180	200
Ød_{1 k6}	20	25	35	40	50	60	70	80
l₁	35	40	60	70	80	110	120	150
Ød_{3 h7}	14	18	22	32	40	50	55	60
l₃	47	50	60	70	95	95	115	130
l₄	32	35	45	50	70	70	80	90
e	37,5	45	55	70	85	105	120	140
f₁	125	140	175	215	255	320	360	425
f₂	–	–	–	–	–	–	–	–
g₁	15	15	15	15	15	20	25	25
g₂	18,5	18	23	25	30	35	40	46
h	52,5	55	60	75	90	105	120	135
k	M6 x12	M6 x12	M8 x15,5	M10 x19,5	M12 x23	M16 x30	M16 x30	M16 x30
m₁	90	100	115	145	175	210	240	275
m₂	58	65	80	97	117	142	162	188
n₁	2	2	2	2	2	2	2	2
n₂	2	2	2	2	2	2	2	2
p	30	36	44	55	67	85	95	110
r_{1**}	M6	M10	M12	M16	M16	M20	M20	M20
r₂	–	–	–	–	–	–	–	–
s	4x M5 x9	4x M5 x12	6x M6 x12	–	–	–	–	–
t	8	8	8	–	–	–	–	–
Øu_{g6}	72,9	87	107	–	–	–	–	–
Øv	62	76	92	–	–	–	–	–
Key_{d1}	6x6x28	8x7x32	10x8x50	12x8x63	14x9x70	18x11x100	20x12x110	22x14x140
Key_{d2}	5x5	6x6	6x6	10x8	12x8	14x9	16x10	18x11

** According to Form D, DIN332

Selection

For entire PowerGear range

POWER GEAR

Performance P [kW] at n_1 [min^{-1}]
 $(P_1 \approx P_2 \text{ at } \eta \geq 98 \%)$
 Ratio i
 Speed $n_1, n_2 = n_1/i$
 Output torque T_2 [Nm] = $9550 \cdot \frac{P_2}{n_2}$



Existing output torque $T_{2N\text{exist.}} \leq$ permissible output torque $T_{2N\text{perm.}}$



Maximum existing acceleration torque $T_{2B\text{exist.}} \leq$ maximum permissible acceleration torque $T_{2B\text{perm.}}$
 or up to 10 start-ups per minute



Maximum existing acceleration torque $T_{2B\text{exist.}} \leq$ maximum permissible nominal torque $T_{2N\text{perm.}}$
 or up to 60 start-ups per minute
 Maximum values for start-ups between 10 and 60 start-ups are interpolated



Existing speed $n_{1\text{exist.}} \leq$ nominal speed n_{1N}
 In cases of higher speeds, please contact us as modifications will be necessary
 (pressure lubrication etc., see options on page 18).



Existing performance $P_{\text{exist.}} \leq$ thermal performance limit P_{therm} (20°C, 100% duty cycle)
 The thermal performance limit varies inline with different ambient temperatures and duty cycles. Please use the factors in the table below as guide values. If the existing performance reaches or exceeds the thermal performance, please contact us as modifications will be necessary (additional cooling, see options on page 20).



Radial and axial load of the shafts \leq maximum permissible values $F_{1R\text{max}}, F_{2R\text{max}}, F_{1A\text{max}}, F_{2A\text{max}}$
 These are guide values, dependent on additional loads. Upon request we calculate these values individually.

Factors for the thermal performance limit:

Duty cycle (dc) [%]	100	80	60	40	20
Factor	1.0	1.2	1.4	1.6	1.8

Ambient temperature [°C]	10	20	30	40	50
Factor	1.2	1.0	0.87	0.75	0.62

Selection

For entire PowerGear range

POWER GEAR

Calculation example:

Given: $n_1 = 1448 \text{ min}^{-1}$
 $n_2 = 362 \text{ min}^{-1}$
 $P = 7.5 \text{ kW}$
 $dc = 100\%$
Ambient temperature: 20°C

$$\text{Selection: } i = \frac{n_1}{n_2} \quad i = \frac{1448 \text{ min}^{-1}}{362 \text{ min}^{-1}} = 4$$

$$T_2 = 9550 \cdot \frac{P}{n_2} = 9550 \cdot \frac{7.5 \text{ kW}}{362 \text{ min}^{-1}} = 197.86 \text{ Nm}$$

→ Gearbox P140 4:1

$$\begin{aligned} T_{2\text{Nexist.}} &= 197.86 \text{ Nm} \leq T_{2\text{Nperm.}} = 224 \text{ Nm} \\ n_{1\text{exist.}} &= 1448 \text{ min}^{-1} \leq n_{1\text{N}} = 2000 \text{ min}^{-1} \\ P_{\text{exist.}} &= 7.5 \text{ kW} \leq P_{\text{therm}} = 9.2 \text{ kW} \end{aligned}$$

Selected: P140L 4:1

Installation positions/Mounting positions

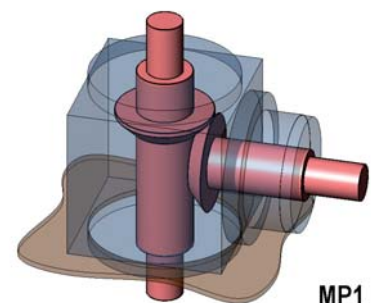
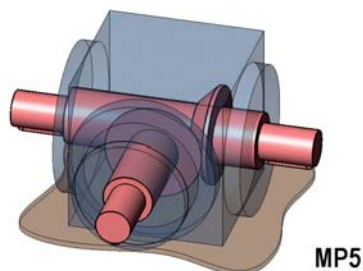
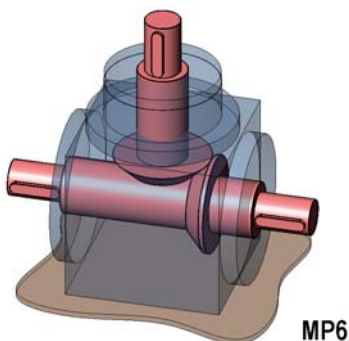
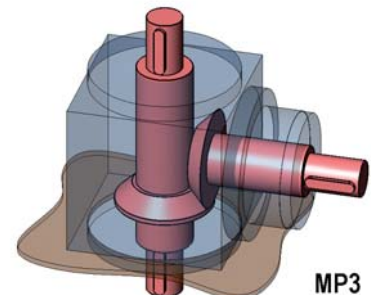
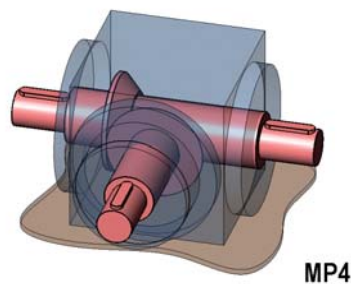
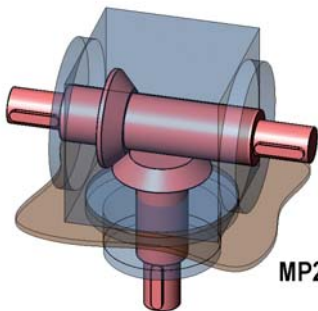

Options

Additional Cooling

1. Oil circulation lubrication system for better cooling

Gearbox is supplied ready for connection to an external oil supply. The external oil supply consists of at least an oil tank, air-oil cooler, an oil pump and pipework between oil tank and gearbox.

2. Cooling packs

Gearbox heat dissipation is increased through mounted aluminium fins

3. Cooling packs with additional fan

Gearbox heat dissipation is increased through mounted aluminium fins and an additional radial fan

4. Water cooling

Gearbox is supplied ready for connection to an external water cooler. The oil reservoir is cooled by a cooling coil.



Oil pressure lubrication

For high speeds it may be necessary to use a forced lubrication for the gear teeth and bearings.

To achieve this, the gearbox is connected to an external pressure lubrication system (similar to the circulation lubrication system).

Oil pressure lubrication can also be combined with additional cooling.

Standard is splash lubrication.



Viton shaft seals

Necessary, if high gearbox temperatures are expected

Square motor flange

For all F Series gearboxes (standard = round flanges)

Gearboxes with minimal backlash

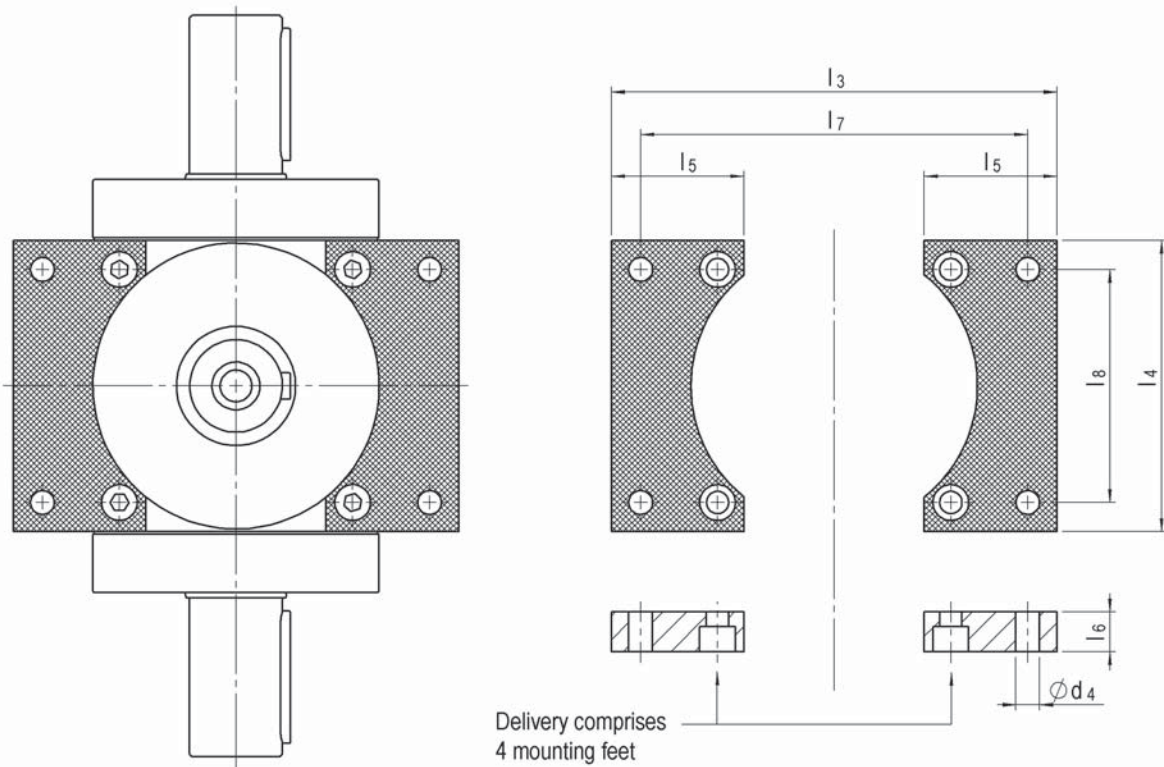

Universal mounting feet

	l 3 (mm)	l 4 (mm) - 0.5	l 5 (mm)	l 6 (mm)	l 7 (mm) + - 0.2	l 8 (mm) + - 0.2	Ød4 (mm)	Cylindrical screw DIN 912	Weight per pair (kg)
P075	122	75	40	17	108	60	6.6	M 6 x 12	0.6
P090	145	90	45	17	125	72	6.6	M 6 x 12	0.8
P110	168	110	50	17	146	88	9.0	M 8 x 18	1.1
P140	208	140	60	20	178	110	11.0	M 10 x 25	1.9
P170	250	170	70	20	215	134	14.0	M 12 x 25	2.7
P210	310	210	90	25	265	170	18.0	M 16 x 35	5.2
P240	345	240	100	30	295	190	18.0	M 16 x 35	8.0
P280	385	280	100	30	335	220	18.0	M 16 x 35	9.6
P360	480	360	125	30	430	280	22.0	M 20 x 40	15.0
P450	580	450	140	30	520	350	22.0	M 20 x 40	21.2

Oil filling

Our gearbox sizes P54 to P140 (X75 to X140) are filled as standard with synthetic oil.

For sizes P170 to P450 (X170 to X280), oil filling requires additional ordering.

On request, we can also fill the gearboxes with **food quality recognised (USDA) oil**.

Shorter shafts

Possible for existing shafts

Plain shafts

(Without keyways) are possible

Customised designs

Further customised designs available on request.

Lubricant	Speed up to/ above min ⁻¹	Viscosity ISO VG DIN 51519 at 40 °C (mm ² /s)	Product				
			Castrol	Castrol performance	Shell	Mobil	Klüber
Mineral oils	500	VG 220	Alpha SP 220	Optigear EP 220 Tribol 1100/220	Shell Omala F220 Shell Omala 220	Mobilgear 600 XP 220	Klüberoil GEM 1-220 N
	1000	VG 150	Alpha SP 150	Optigear EP 150 Tribol 1100/150	Shell Omala F150 Shell Omala 150	Mobilgear 600 XP 150	Klüberoil GEM 1-150 N
	1500	VG 100	Alpha SP 100	Optigear EP 100 Tribol 1100/100	Shell Omala F100 Shell Omala 100	Mobilgear 600 XP 100	Klüberoil GEM 1-100 N
	above 2000	VG 68	Alpha SP 68		Shell Omala 68	Mobilgear 600 XP 68	Klüberoil GEM 1-68 N
Mineral oils for hypoid drives	up to 2000	SAE category 85W-90				Mobilube HD-A 85W-90	
	above 2000	SAE category 80W				Mobilube GX-A 80W	
Synthetic gear oil	500	VG 220	**Alphasyn GS 220	**Tribol 800/220	Shell Tivela S 220 Shell Cassida WG 220	Mobil Glygoyle 30	Klübersynth GH 6-220
Polyglycols (CLP-PG)	1000	VG 150	**Alphasyn GS 150	**Tribol 800/150	Shell Tivela S150 Shell Cassida WG 150	Mobil Glygoyle 22	Klübersynth GH 6-150
	start at 2000	VG 100		**Tribol 800/100		Mobil Glygoyle 11	Klübersynth GH 6-100
Synthetic gear oil	500	VG 220	*Alphasyn EP 220	*Optigear Synthetic PD 220	Shell Omala HD 220	Mobil SHC 630 Mobil SHC Gear 220	Klübersynth GEM 4-220 N
Poly- α -Olefine (CLP-HC)	1000 (3000)	VG 150	*Alphasyn EP 150	*Optigear Synthetic PD 150	Shell Omala HD 150	Mobil SHC 629 Mobil SHC Gear 150	Klübersynth GEM 4-150 N
	1500	VG 100				Mobil SHC 627	
	start at 1500	VG 68				Mobil SHC 626	
Physiologically uncritical oils (PHY-Oil)	1000	VG 220		*Optileb GT 220 **Tribol FoodProof 1800/220	Shell Cassida WG 220	Mobil SHC Cibus 220	*Klüberoil 4 UH1 – 220 N **Klübersynth UH1 6-220
USDA - H1 Certified	1500	VG 150		*Optileb GT 150		Mobil SHC Cibus 150	*Klüberoil 4 UH1 – 150 **Klübersynth UH1 6-150
NSF H1 Certified	start at 1500	VG 100		*Optileb GT 100		Mobil SHC Cibus 100	*Klüberoil 4 UH1 - 68 N

* Synth. KW-Oil, Ester Oil ** Polyglycol Oil

Oil quantities (dependent on ratio, speed, shaft arrangement and installation position)

Size	P54	P75/X75	P90/X90	P110/X110	P140/X140	P170/X170	P210/X210	P240/X240	P280/X280	P360	P450
Average max amount of oil	0,05 l	0,1 l	0,2 l	0,3 l	0,4 l	1,0 l	2,2 l	2,6 l	3,0 l	9,0 l	22,0 l
	-	-	-	0,35 l	0,6 l	1,2 l	2,5 l	3,5 l	5,0 l	15,0 l	32,0 l

When changing oil, we recommend that you fill the gear unit with the type of oil previously used. In particular, synthetic oils may not be mixed with mineral oils or other synthetic oils. When changing from mineral oil to synthetic oil, the gearbox must be rinsed thoroughly with new oil type.

POWERGEAR gearboxes, size P75 to P140 and X75 to X140 are supplied ready lubricated for life with a high-quality Poly-Alpha-Olefin synthetic oil. They are therefore maintenance free. Up to size P110/X110 there are no oil drain holes included. Only from size P140/X140 do the gearboxes include oil drain holes to enable optional oil changes.

POWERGEAR gearboxes, size P170 to P450 and X170 to X280 are supplied without lubricant if not ordered additionally.

For operating temperatures of max 80 °C, we recommend the use of mineral gear oil CLP DIN 51517 to ISO VG-Class 100 (DIN 51519).

For operating temperatures of up to 90 °C, we recommend the use of Poly-Alpha-Olefin synthetic gear oil CLP DIN 51517, part 3, to ISO VG-Class 150 (DIN 51519).

The lifespan of the oil at 80 °C average temperature in the gearbox without any relevant change in the quality of the oil, indicated by the oil producers are maximum values:

- for mineral oils, biodegradable oil and physiologically uncritical oil at least 2 years or 10.000 operating hours
- for Poly-Alpha-Olefine and Polyglykole at least 4 years or 20.000 operating hours

Please note:

The actual lifespan may be longer but for temperatures of over 80 °C could equally be shorter. As a rule, the lifespan of the oil is reduced by 50% for an operating temperature increase of 10 °C.

The condition of the gearbox and especially the leak tightness requires checking at regular intervals.

Service kits of wear and tear parts with full instructions are available from our service department.

P	-	075	-	L	-	1,00:1	-	WA 1	
1.		2.		3.		4.		5.	6.

- | | | |
|-----------------------------|-------------------------------------------|--------------------|
| 1. Gearbox range | P = PowerGear Standard | Page 6+7 |
| | X = PowerGear Reinforced Design | Page 8 |
| 1. Size | | Page 6-8 |
| 3. Series | L – Solid shaft | Page 10+12/Page 16 |
| | FL – Solid shaft with flange | Page 14 |
| | H – Hollow shaft | Page 11+13/Page 17 |
| | FH – Hollow shaft with flange | Page 15 |
| 4. Ratio | | Page 6-8 |
| 5. Shaft arrangement | | Page 10–17 |
| 6. Additional data | • Installation Position | Page 19 |
| | • Input speeds | |
| | Maximum application speed | |
| | for configurations FL/FH, please indicate | |
| | d1, flange version B5 or B14 | |
| | and flange diameter | Page 14+15 |
| | • Options – on request | Page 20+21 |
| | • Customised design – on request | |

Please note that

All Information contained in this catalogue is provided without guarantee and is not binding. In particular, dimensions and values only provide guidance. Any exact, specific requirements must be agreed with us. Specifications and features listed in the catalogue are subject to a written contract.



Germany

MS-GRAESSNER GmbH & Co. KG
THE GEAR COMPANY
Kuchenäcker 11
72135 Dettenhausen
Tel.: +49 (0) 7157 123-0
Fax: +49 (0) 7157 123-212
E-Mail: mail@graessner.de
www.graessner.de



Austria

GRAESSNER GmbH
Perfektastraße 61
Objekt 6/2
1230 Wien
Tel.: +43 (1) 6992430-0
Fax: +43 (1) 6992430-20
E-Mail: graessner@graessner.at
www.graessner.at

Further information regarding the distribution network of MS-GRAESSNER can be found on:
www.graessner.com

BEVEL GEAR

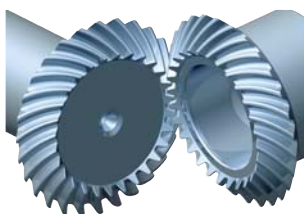

Spiral, Hypoid and Zerol Bevel Gears

- Standard range of products and custom-made versions
- Module ms from 0.5 to 12
- Diameters up to 410 mm
- Shaft angles from 10° to 170°
- More than 60 years of experience
- In-house gearing calculations
- We manufacture to your drawing or advise you of possible alternatives
- Milled or ground gear tooth cutting

POWER GEAR



The high performance bevel gearbox

- High torque, small size
- For highest input speeds
- Ratios from $i = 1:1$ to 5:1
- Torques up to 7000 Nm
- Output via solid and hollow shaft
- Motor mounting either directly or via coupling and lantern
- Variable ratios and uniform dimensions

DYNA GEAR



The highly dynamic servo right angle gearbox

- Hypoid gearing
- High input speeds at medium to high torques
- Ratios single-stage $i = 3:1$ to 30:1
- Ratios, two-stage, up to 150:1
- Torques up to 1440 Nm
- Flexible motor mounting via coupling and lantern
- Low backlash < 2 arcmin
- Variable ratios and uniform dimensions

DYNA GEAR ^{Economy} The cost-effective servo right angle gearbox



- Hypoid gearing
- High input speeds at medium torques
- Ratios single-stage $i = 5:1, 8:1, 10:1$ and 15:1
- Torques up to 260 Nm
- Flexible motor mounting via coupling and flange
- Backlash < 6 arcmin
- Variable ratios and uniform dimensions

DESIGN GEAR The customised gearbox



- Single-stage gearbox available as gear-change or reversing gearbox
- Forced oil circulation lubrication system gearbox for high speeds and torques
- Labyrinth sealed gearbox with an efficiency of > 99%
- Special gearbox with additional functional elements
- Endless possibilities on request

KS TWIN GEAR The bevel helical gearbox

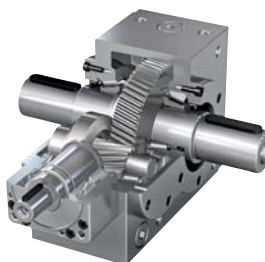

- Two-stage bevel helical gearbox with ratios of up to 75:1
- Torques up to 7500 Nm
- Torsional backlash < 6 arcmin
- Compact design
- Motor mounting either directly or via coupling and lantern
- High torsional stiffness
- High input speeds at high torques