

MS-GRAESSNER ENGINEERING

For everyone who expects more:
special gearboxes from the specialist

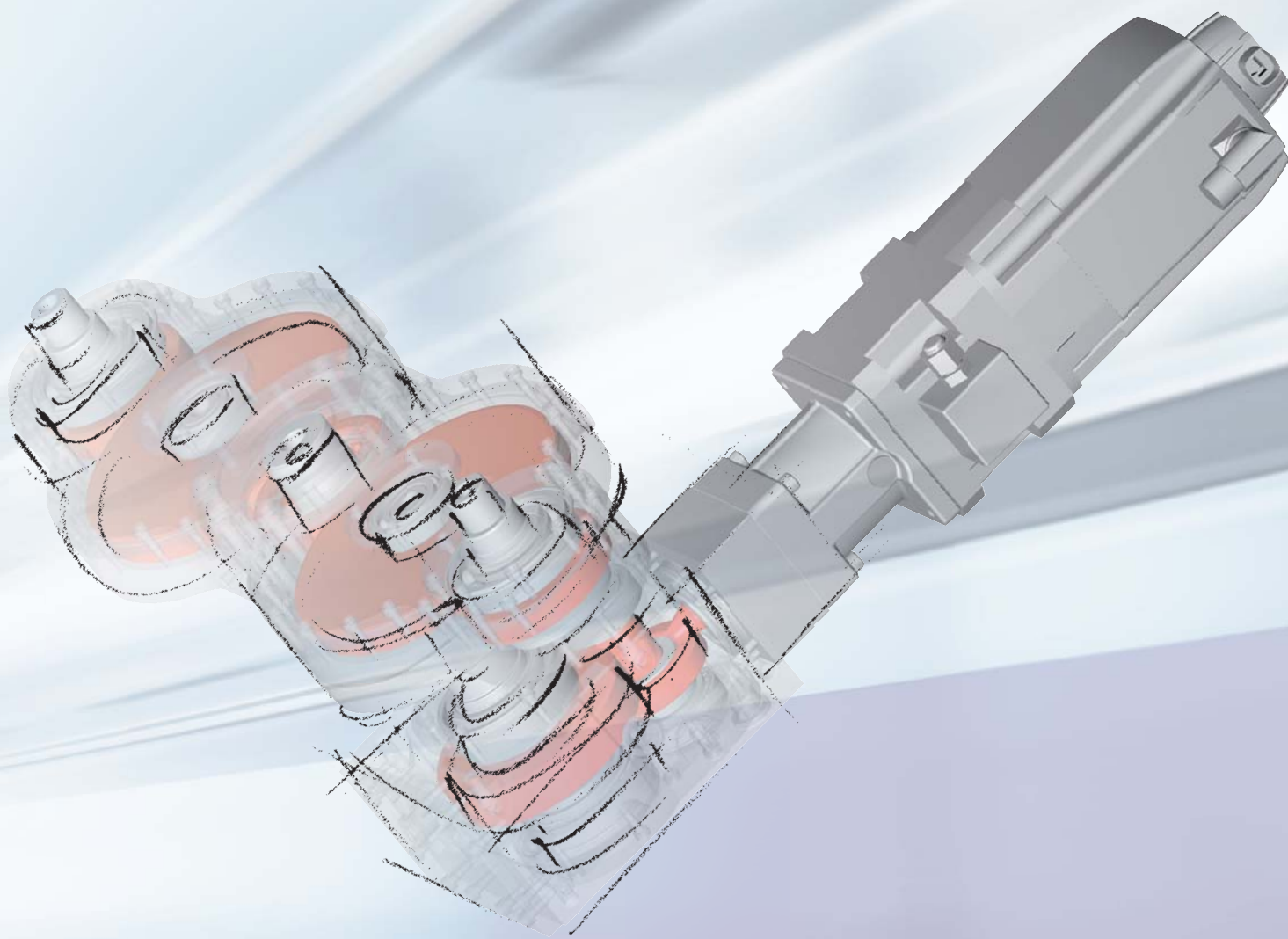

Driven by your requirements

Our engineering and special manufacturing techniques have helped us become precision manufacturer of tooth systems and bevel gearboxes for almost 60 years, as well as specialist in special gearboxes.

For us, individual solutions are standard. And instead of offering expertise that's confined to certain areas, like pure development for instance, we offer comprehensive know-how in all relevant areas – from the specifications and the first sketch up to the manufacturing of the zero series including intensive test operations.

Our expertise also extends to a special in-house developed workflow management system: for optimal processes between all areas involved and the customer. Our quality management system thus guarantees highest quality and cost certainty.

Four examples illustrating one principle: highly individual special gearboxes

We offer a production-compatible design, specially adapted to the customer's applications, with innovatively designed drive sections, including planetary, spur gear, bevel and worm gear stages. We are driven by the desire to support our customers in the new development and optimisation of their tooth system designs through the innovative and sustainable development of special gearboxes.

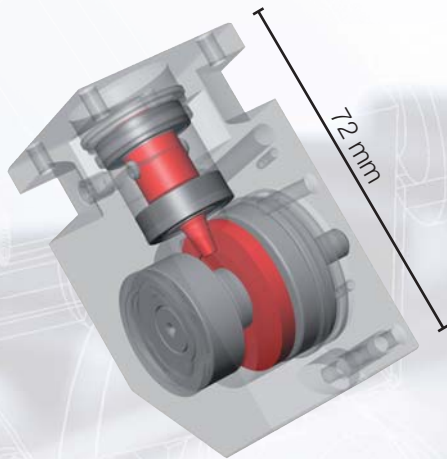

High transmission miniature gearbox for applications in the automotive industry and in medical technology.

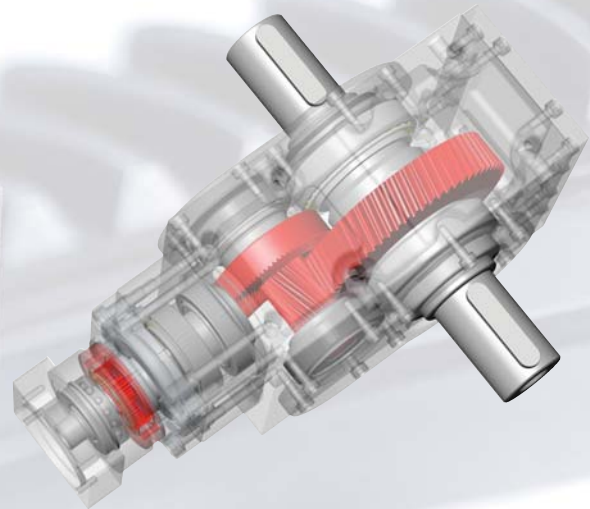

Three-stage angle gearbox for ratios $> i = 75:1$; planetary gear stage including spur gear and bevel gear stage. For machine tool and plant construction applications.

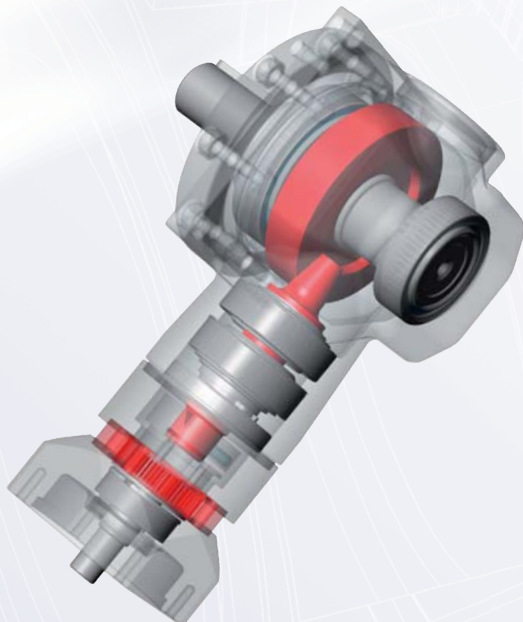

Innovative planetary gearbox for ratios up to $i = 150:1$; planetary gear and hypoid bevel gear stage. For applications in automation and robotics.

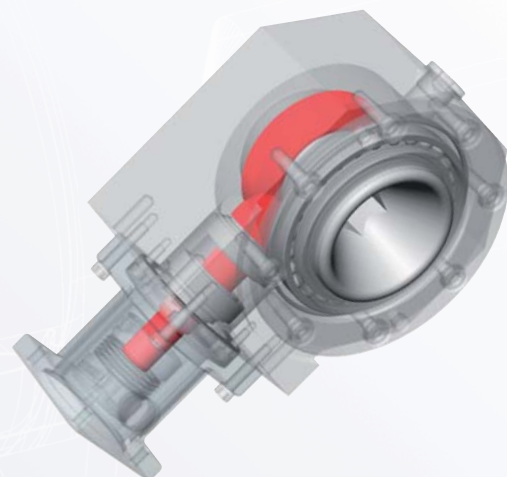

High transmission single-stage angle gearbox in a slim-line, lightweight design for highly dynamic loads. For applications in the food and packaging machine industry.

We are only satisfied with the best solution, not with the first one that comes along.

MS-Graessner has many years of experience as well as comprehensive know-how for special tasks, this is exactly what is required for the development of special gearboxes. From the individual drive section to the calculation of the complete drive train, a highly specialised, state of the art CAD-based developer software enables the accurate development and construction. The entire development process takes place in close cooperation with the customer.



GEARFOX Software

MS-Graessner's own, internet-based software GEARFOX enables the calculation of the entire drive train. This begins with the analysis of the customer needs, includes the definition of the product requirements, the calculation of applications as well as the gear design and culminates in an iterative gearbox optimisation.



Further advantages: process acceleration through pre-defined calculation models and verified, extensive data-bases.

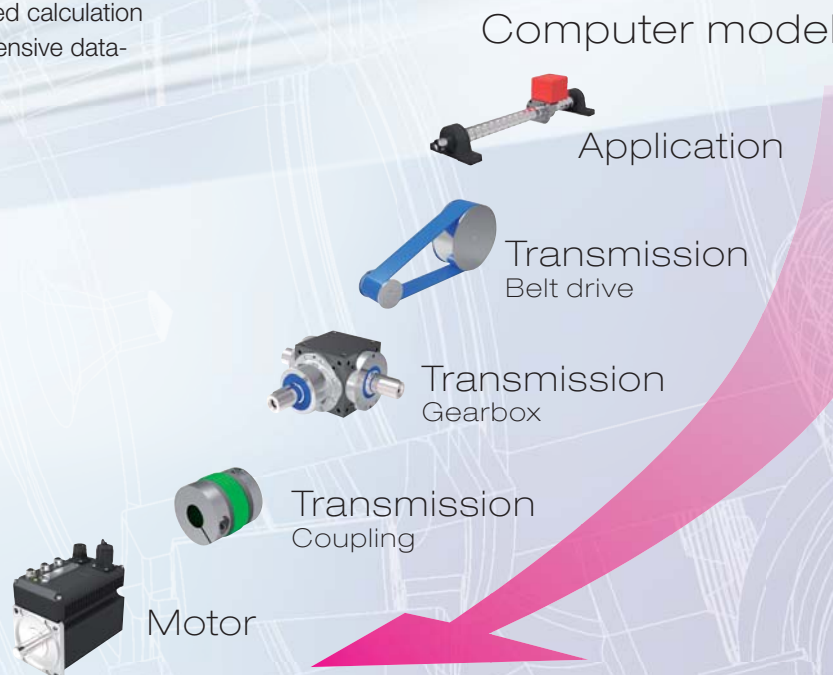

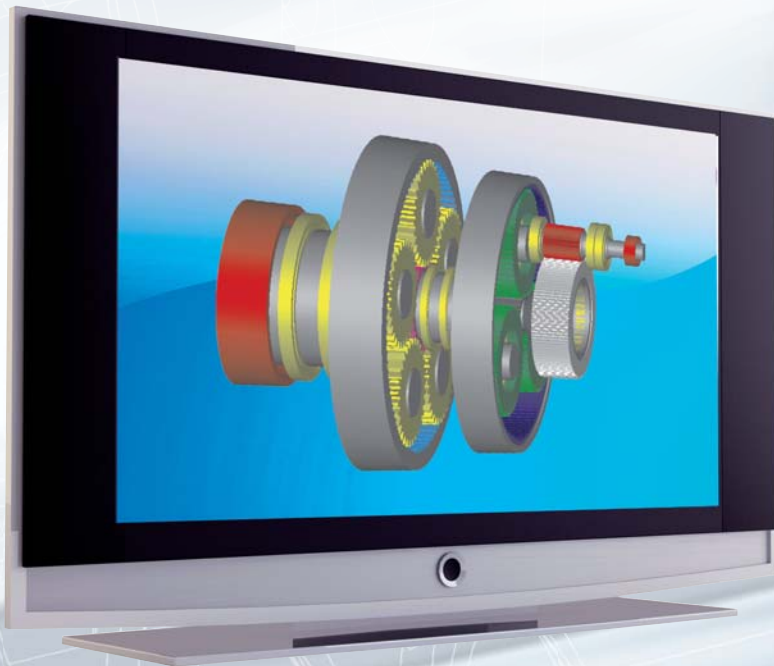

KISSsoft Software

The KISSsoft software calculates, designs and optimises the gearbox components. The following parameters are calculated and considered amongst others: forces/torques, bending stress, strength, mass, stiffness, tension/pressure, transverse/axial forces, Hertzian stress, safety processes as well as special sliding.

Toothing calculation

Gleason software optimises the design of individual components, like gear wheels for example: it covers tooth dimensions, gear tooth load data and meshing forces. It also deals with tooth contact analysis, the outline of the contact geometry as well as an extended calculation method of the tooth contact. The finite element analysis enables the calculation of the contact pattern under load and also provides information about the tooth base bending stress, surface pressure, the Wöhler curve and much more. All designs and simulations are also carried out using special CAD software.

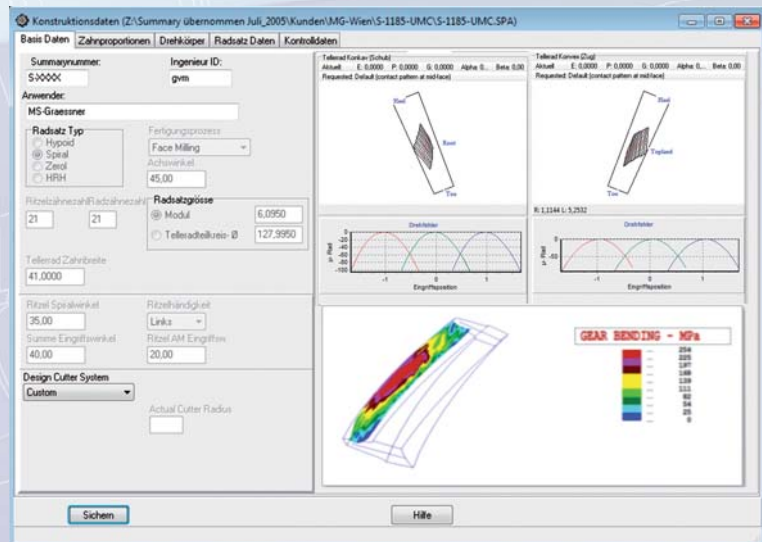

Short development times, optimal configuration and perfect results: it can only be our workflow management system.

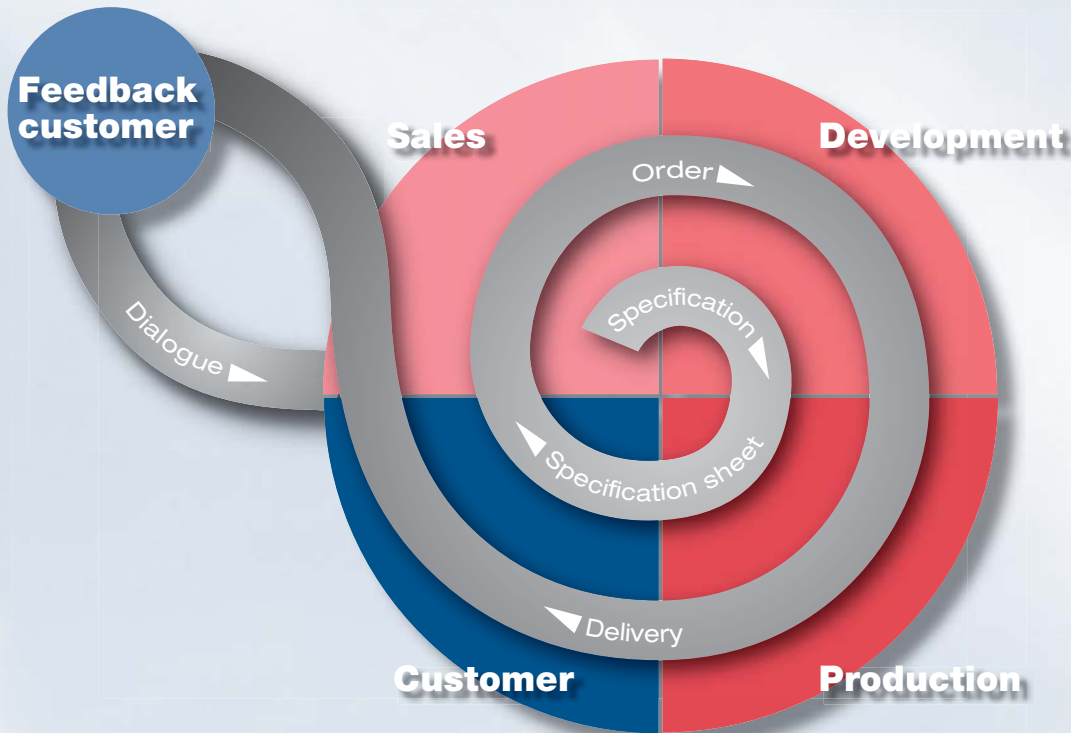

Our in-house, continually optimised MS-Graessner workflow management system guarantees an optimal engineering process: in an iterative, itself meaningfully repeating process with defined interfaces – closed loop (manufacturing loop) – all areas involved, including sales, development, production and customer, are integrated at an early stage and at all relevant points. Thus the optimal coordination of all departments involved is guaranteed at every stage of the engineering process. This benefits quality assurance, communication and thus the acceleration of innovation and product cycles.

This workflow system also guarantees that possible requests for modification from the customer are integrated into the engineering process as soon as possible. Changes are cheaper to implement the earlier they are taken into account. Our expertise, in combination with customer feedback and lessons from the project, also continually improves the project management.

Workflow advantages

- Shorter innovation and product cycles
- Better communication through the involvement of all participants
- Large knowledge base
- Guided resources and capacities
- Cost savings

Reduction of the development time

Given that the traditional development time from the concept development to start-up takes approximately 8 months, the MS-Graessner workflow management system substantially reduces the development time. The combination of working closely with the customer and the earlier, more cost-effective consideration of change requests means a successful outcome for individual engineering jobs.

Before it reaches you, we put your gearbox through hell!

Practice is key. MS-Graessner's manufacturing expertise is the prerequisite for a production-ready gearbox, right from the start, because in addition to nearly 60 years' experience making gearboxes, we also have the necessary skills and appropriate inspection and test procedures to check a newly developed gear through its paces. To paraphrase the old engineer's saying: confidence is good. Hardness tests are better.



The function of the gearboxes, both while idling and under load, is intensively tested, while years of real time exposure is simulated on various test rigs. These tests can be carried out both in continuous and cycle operation.



High precision equipment, including documentation, guarantees extremely high-quality gearbox assembly.



Our digitally-networked, CNC-controlled tool and measuring machines ensure highest quality as well as information about tolerances and run outs of drive sections.



The latest CNC machines make tooth grinding possible as well as interior and external grinding in a single setting.



Form-locked and friction-locked shaft-hub connections are also among our specialities.

DYNA GEAR

The highly dynamic servo right angle gearbox



DYNA GEAR *Economy*

The cost-effective servo right angle gearbox

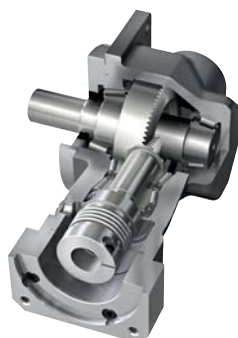

DESIGN GEAR

The customised gearbox



BEVEL GEAR

Spiral, Hypoid and Zerol Bevel Gears

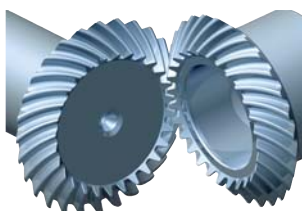

POWER GEAR

The high performance bevel gearbox



KS TWIN GEAR

The bevel helical gearbox

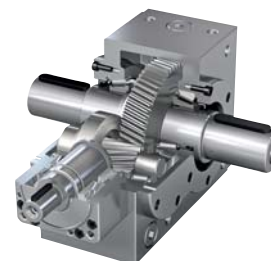

Germany



MS-GRAESSNER GmbH & Co. KG
THE GEAR COMPANY
 Kuchenäcker 11
 72135 Dettenhausen
 Tel.: +49 (0) 71 57 123-0
 Fax: +49 (0) 71 57 123-212
 E-Mail: mail@graessner.de
www.graessner.de

Austria



GRAESSNER GmbH
 Perfektastraße 61
 Objekt 6/2
 1230 Wien
 Tel.: +43 (1) 699 2430-0
 Fax: +43 (1) 699 2430-20
 E-Mail: graessner@graessner.at
www.graessner.at

For more information on MS-GRAESSNER's worldwide distribution network, please visit:
www.graessner.com